

PARTITION PLAT

**HOOD RIVER COUNTY
SURVEYOR'S OFFICE**
Survey No. 2008 061
Filed 9-3-08
By Bradley Ruffmon

RECORDING INFORMATION
Plat Number 200818P
Instrument received on the 27
day of August, 2008,
at 2:12 P.M.
Leah Day-Clerc
Hood River County Director of
Records and Assessments.

TAX LOT 1N-10E-15 600 (REF. #5174 & #5175)
IN THE N.1/2 OF SECTION 15,
TOWNSHIP 1 N., RANGE 10 E., W.M.
HOOD RIVER COUNTY, OREGON
AUGUST 27, 2008

OWNER:
MICHAEL NASTASI
2 BAILEY LANE
BREWSTER, NEW YORK 10509
PH. (845) 279-8381

SURVEYOR'S CERTIFICATE:
I, BRADLEY R. HUFFMON
being first duly sworn, depose and say
that I have correctly surveyed and
marked with proper monuments the
lands represented on this Partition
Plat, the boundaries being described
as Adjusted Tax Lot 1N-12E-15 600
in instrument #2007-4347, dated
September 25, 2007. Hood River
County Deed Records owned by
MICHAEL NASTASI

- LEGEND:**
- ⊙ SET 5/8" REBAR WITH YELLOW PLASTIC CAP, "HUFFMON PLS 2786"
 - ⊙ FOUND 5/8" REBAR W/YPC "2786" PER REF.#8 UNLESS OTHERWISE NOTED
 - CALCULATED CORNERS, NOT SET.
 - SET HUB & TACK.
 - SET P.K. NAIL OR AS NOTED.
 - ◆ SET BRASS SCREW AND WASHER, INSCRIBED "LS 2786"

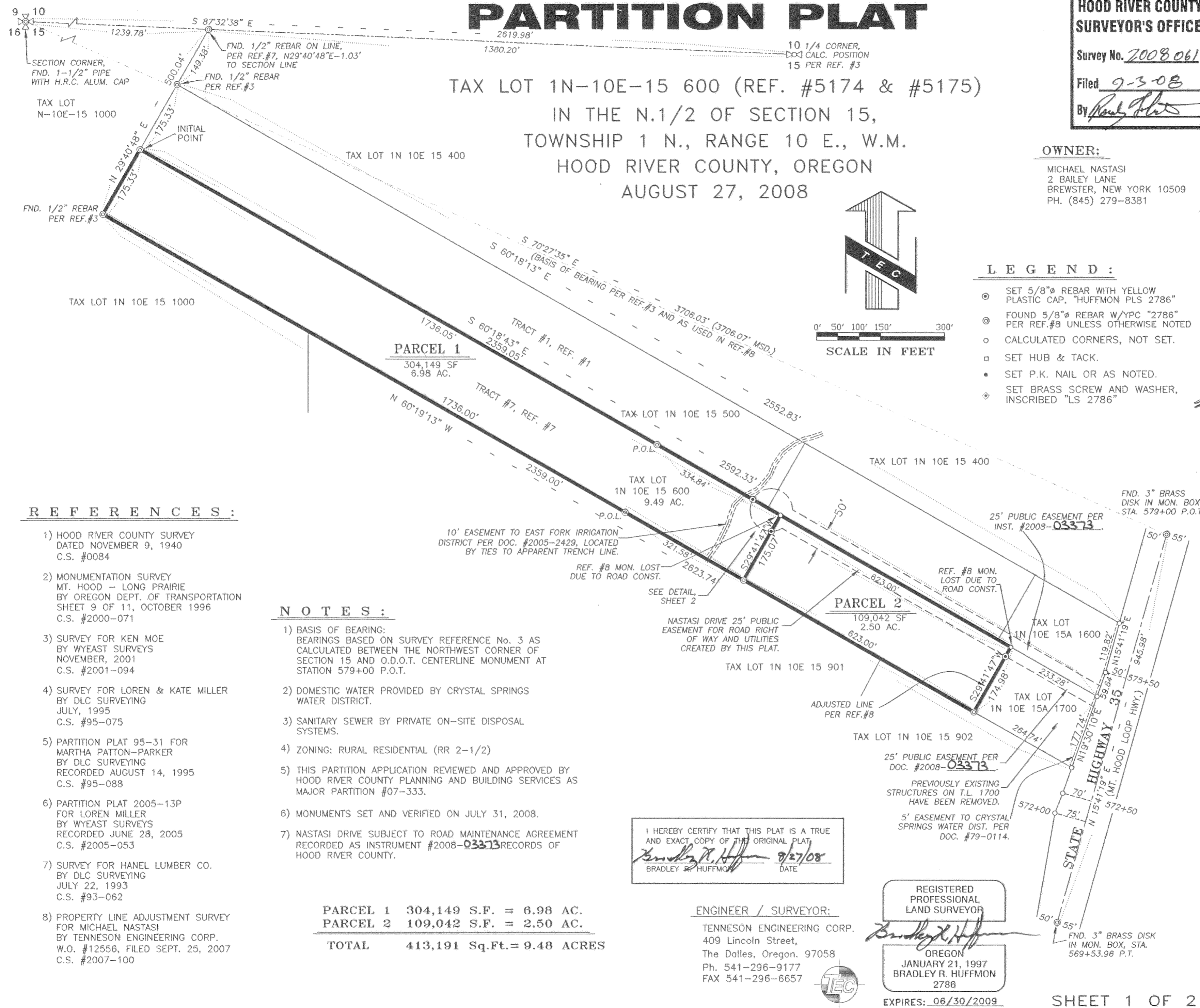
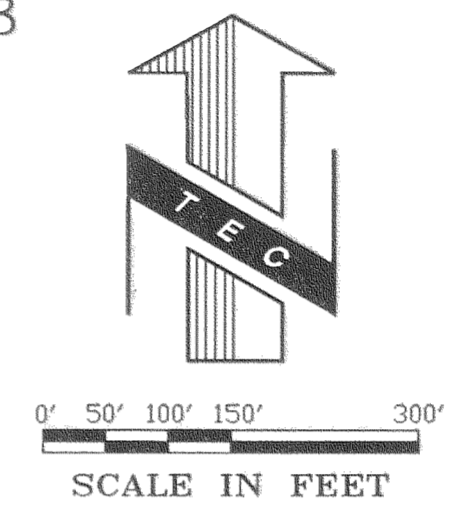

REFERENCES:

- 1) HOOD RIVER COUNTY SURVEY DATED NOVEMBER 9, 1940 C.S. #0084
- 2) MONUMENTATION SURVEY MT. HOOD - LONG PRAIRIE BY OREGON DEPT. OF TRANSPORTATION SHEET 9 OF 11, OCTOBER 1996 C.S. #2000-071
- 3) SURVEY FOR KEN MOE BY WYEAST SURVEYS NOVEMBER, 2001 C.S. #2001-094
- 4) SURVEY FOR LOREN & KATE MILLER BY DLC SURVEYING JULY, 1995 C.S. #95-075
- 5) PARTITION PLAT 95-31 FOR MARTHA PATTON-PARKER BY DLC SURVEYING RECORDED AUGUST 14, 1995 C.S. #95-088
- 6) PARTITION PLAT 2005-13P FOR LOREN MILLER BY WYEAST SURVEYS RECORDED JUNE 28, 2005 C.S. #2005-053
- 7) SURVEY FOR HANEL LUMBER CO. BY DLC SURVEYING JULY 22, 1993 C.S. #93-062
- 8) PROPERTY LINE ADJUSTMENT SURVEY FOR MICHAEL NASTASI BY TENNESON ENGINEERING CORP. W.O. #12556, FILED SEPT. 25, 2007 C.S. #2007-100

NOTES:

- 1) BASIS OF BEARING: BEARINGS BASED ON SURVEY REFERENCE No. 3 AS CALCULATED BETWEEN THE NORTHWEST CORNER OF SECTION 15 AND O.D.O.T. CENTERLINE MONUMENT AT STATION 579+00 P.O.T.
- 2) DOMESTIC WATER PROVIDED BY CRYSTAL SPRINGS WATER DISTRICT.
- 3) SANITARY SEWER BY PRIVATE ON-SITE DISPOSAL SYSTEMS.
- 4) ZONING: RURAL RESIDENTIAL (RR 2-1/2)
- 5) THIS PARTITION APPLICATION REVIEWED AND APPROVED BY HOOD RIVER COUNTY PLANNING AND BUILDING SERVICES AS MAJOR PARTITION #07-333.
- 6) MONUMENTS SET AND VERIFIED ON JULY 31, 2008.
- 7) NASTASI DRIVE SUBJECT TO ROAD MAINTENANCE AGREEMENT RECORDED AS INSTRUMENT #2008-03373 RECORDS OF HOOD RIVER COUNTY.

PARCEL 1 304,149 S.F. = 6.98 AC.
PARCEL 2 109,042 S.F. = 2.50 AC.
TOTAL 413,191 Sq.Ft. = 9.48 ACRES

I HEREBY CERTIFY THAT THIS PLAT IS A TRUE AND EXACT COPY OF THE ORIGINAL PLAT.
Bradley R. Huffmon 8/27/08
BRADLEY R. HUFFMON DATE

ENGINEER / SURVEYOR:
TENNESON ENGINEERING CORP.
409 Lincoln Street,
The Dalles, Oregon. 97058
Ph. 541-296-9177
FAX 541-296-6657

REGISTERED PROFESSIONAL LAND SURVEYOR
Bradley R. Huffmon
OREGON
JANUARY 21, 1997
BRADLEY R. HUFFMON
2786

EXPIRES: 06/30/2009

DECLARATION:
I Michael Nastasi the owner of the land shown herein, hereby declare that this division of land has been made with my free consent and in accordance with my desires and in this plat create the public easement shown hereon for the stated purpose.
Michael Nastasi 8/27/08
MICHAEL NASTASI DATE
Wayne C. Annala 8/27/08
BY WAYNE C. ANNALA DATE
HIS ATTORNEY-IN-FACT
PER INS. #2008-03352

ACKNOWLEDGEMENT:
State of Oregon
County of Hood River
This instrument was acknowledged before me on August 27, 2008 by Wayne Annala
Sandi Sohler
(signature of notarial officer)
Sandi Sohler
(printed name of notarial officer)
COMMISSION No. 424279
MY COMMISSION EXPIRES Feb. 11, 2012

APPROVALS:
I, hereby certify that I have examined the Survey Data, Monuments and Easements and hereby approve this plat on the 27th day of August, 2008.
Bradley Ruffmon
Hood River County Surveyor
I, hereby certify that all taxes and assessments due hereon have been fully paid as required by law and hereby approve this plat.
Michael Boroy
Hood River County Director of Budget and Finance.
I hereby certify that this partition plat was examined and approved as of this 27th day of August, 2008.
Planning File Number 07-333
M. Benedict
Hood River County Planning Director

PARTITION PLAT

TAX LOT 1N-10E-15 600 (REF. #5174 AND #5175)
 IN THE N.1/2 OF SECTION 15,
 TOWNSHIP 1 N., RANGE 10 E., W.M.
 HOOD RIVER COUNTY, OREGON
 AUGUST 27, 2008

HOOD RIVER COUNTY
 SURVEYOR'S OFFICE

Survey No. 2008 061

Filed 9-3-08

By Bradley R. Huffmon

RECORDING INFORMATION
 Plat Number 200818P
 instrument received on the 27
 day of August, 2008,
 at 2:12 P.M.
Josh Day - Clerk
 Hood River County Director of
 Records and Assessments.

OWNER:

MICHAEL NASTASI
 2 BAILEY LANE
 BREWSTER, NEW YORK 10509
 PH. (845) 279-8381

CURVE	DELTA	RADIUS	ARC LENGTH	TANGENT	CHORD BEARING	CHORD LENGTH
C3	119°59'30"	50.00'	104.71'	86.59'	S 30°18'28" E	86.60'
C4	30°00'30"	50.00'	26.19'	13.40'	N 74°41'32" E	25.89'

PARCEL 1 304,149 S.F. = 6.98 AC.
 PARCEL 2 109,042 S.F. = 2.50 AC.
TOTAL 413,191 Sq.Ft. = 9.48 ACRES

LEGEND:

- ⊙ SET 5/8"Ø REBAR WITH YELLOW PLASTIC CAP, "HUFFMON PLS 2786"
- ⊙ FOUND 5/8"Ø REBAR W/YPC "2786" PER REF.#8 UNLESS OTHERWISE NOTED
- CALCULATED CORNERS, NOT SET.
- SET HUB & TACK.
- SET P.K. NAIL OR AS NOTED.
- ⊙ SET BRASS SCREW AND WASHER, INSCRIBED "LS 2786"

EASEMENT LISTING:

- THE FOLLOWING EASEMENT LISTING IS PER AMERITITLE SUBDIVISION GUARANTEE, ORDER #39409, DATED JULY 9, 2008. THE NUMBERING FOLLOWS THIS REPORT.
3. EASEMENT TO PACIFIC POWER AND LIGHT COMPANY FOR ELECTRIC TRANSMISSION DISTRIBUTION LINE AND APPURTENANCES PER BOOK 7, PAGE 187. THE SUBJECT PROPERTY IS WITHIN THE LANDS DESCRIBED IN THIS DOCUMENT. NO EXISTING OVERHEAD OR UNDERGROUND POWER LINES EXIST ON THE PROPERTY THAT APPEAR TO COINCIDE WITH THIS EASEMENT. NO MAPPING IS SHOWN ON THE PARTITION ATTRIBUTED TO THIS EASEMENT.
 4. RELINQUISHMENT OF ALL EXISTING AND FUTURE RIGHTS TO RIGHTS OF ACCESS TO AND FROM THE STATE HIGHWAY AND TERMS THEREOF CONTAINED IN WARRANTY DEED PER DOCUMENT #78-0803. THE SUBJECT PROPERTY REMAINS SUBJECT TO THE STATE HIGHWAY ACCESS CONSIDERATIONS STATED THEREIN. THERE IS NO MAPPING ON THE PARTITION RELATED TO THIS DOCUMENT.
 5. EASEMENT FOR PIPELINES TO CRYSTAL SPRINGS WATER DISTRICT PER DOCUMENT #79-0114. THIS EASEMENT LIES ADJACENT TO THE HIGHWAY 35 RIGHT-OF-WAY. IT DOES NOT LIE ON THE LAND BEING PARTITIONED. FOR REFERENCE PURPOSES, IT IS SHOWN ON THE PARTITION MAP.
 6. EASEMENT FOR PIPELINES TO EAST FORK IRRIGATION DISTRICT PER DOCUMENT #2005-2429. THIS EASEMENT IS 10 FEET IN WIDTH AND IS SHOWN ON THE MAP BY TIES MADE TO THE APPARENT TRENCH LINE.

REFERENCES:

- 1) HOOD RIVER COUNTY SURVEY DATED NOVEMBER 9, 1940 C.S. #0084
- 2) MONUMENTATION SURVEY MT. HOOD - LONG PRAIRIE BY OREGON DEPT. OF TRANSPORTATION SHEET 9 OF 11, OCTOBER 1996 C.S. #2000-071
- 3) SURVEY FOR KEN MOE BY WYEAST SURVEYS NOVEMBER, 2001 C.S. #2001-094
- 4) SURVEY FOR LOREN & KATE MILLER BY DLC SURVEYING JULY, 1995 C.S. #95-075
- 5) PARTITION PLAT 95-31 FOR MARTHA PATTON-PARKER BY DLC SURVEYING RECORDED AUGUST 14, 1995 C.S. #95-088
- 6) PARTITION PLAT 2005-13P FOR LOREN MILLER BY WYEAST SURVEYS RECORDED JUNE 28, 2005 C.S. #2005-053
- 7) SURVEY FOR HANEL LUMBER CO. BY DLC SURVEYING JULY 22, 1993 C.S. #93-062
- 8) PROPERTY LINE ADJUSTEMENT SURVEY FOR MICHAEL NASTASI BY TENNESON ENGINEERING CORP. W.O. #12556, FILED SEPT. 25, 2007 C.S. #2007-100

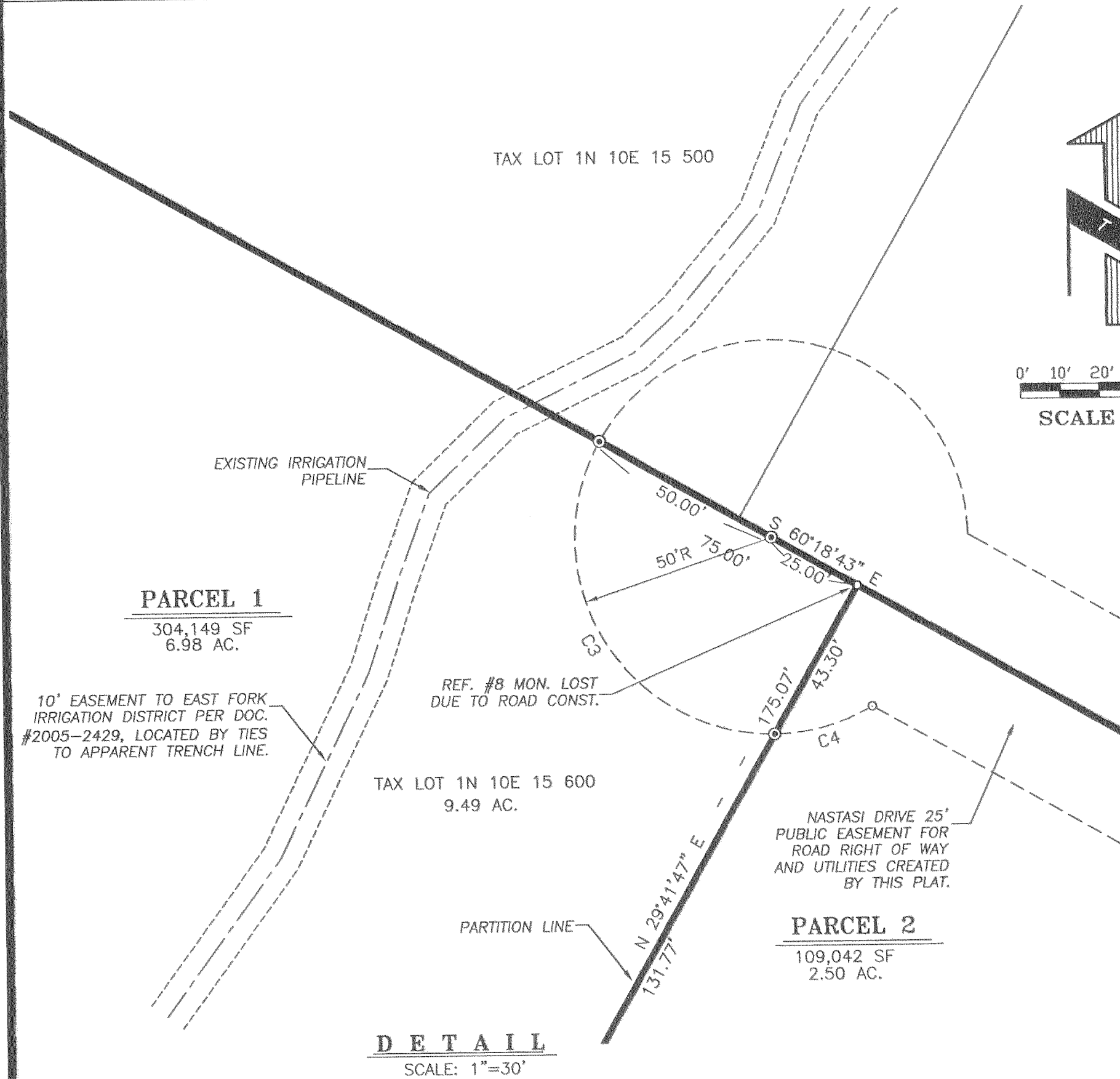

DETAIL
 SCALE: 1"=30'

NARRATIVE:

THE PURPOSE OF THIS SURVEY WAS TO COMPLETE A TWO PARCEL PARTITION OF TAX LOT 1N-10E-15 600. NUMEROUS PRIOR SURVEYS HAVE BEEN CONDUCTED ON AND IN THE VICINITY OF THE SUBJECT PROPERTY. KEY SURVEYS ARE LISTED AS REFERENCES. THE PRIMARY REFERENCE UTILIZED WAS #8, A PROPERTY LINE ADJUSTMENT SURVEY WHICH CREATED THE PROPERTY IN IT CURRENT CONFIGURATION. THE BOUNDARY SHOWN HEREON IS IDENTICAL TO THE PROPERTY LINE ADJUSTMENT SURVEY.

MONUMENTS WERE RECOVERED AND/OR RESET ON THE BOUNDARY AND PARTITION LINES AS SHOWN. THIS PARTITION ALSO CREATES THAT PORTION OF NASTASI DRIVE LYING WITHIN ITS BOUNDARY. NASTASI DRIVE IS A PUBLIC EASEMENT FOR ROAD RIGHT-OF-WAY AND UTILITIES. THE REMAINING PORTION OF NASTASI DRIVE WILL BE CREATED BY PARTITION OF THE NASTASI PROPERTY ADJOINING THIS PROPERTY TO THE NORTH. THE PLAT ALSO SHOWS EASEMENTS OF RECORD PER CURRENT SUBDIVISION GUARANTEE.

SET MONUMENTS ARE 5/8" X 30" REBAR WITH YELLOW PLASTIC CAP INSCRIBED "HUFFMON PLS 2786".

SURVEYOR'S CERTIFICATE:

I, BRADLEY R. HUFFMON, REGISTERED LAND SURVEYOR NO. 2786 IN THE STATE OF OREGON, BEING FIRST DULY SWORN, DEPOSE AND SAY THAT I HAVE CORRECTLY EXECUTED, ACCORDING TO ORS CHAPTER 92 AND THE HOOD RIVER COUNTY ZONING ORDINANCE, A PARTITION PLAT LYING IN THE NORTH 1/2 OF SECTION 15, TOWNSHIP 1 NORTH, RANGE 10 EAST, WILLAMETTE MERIDIAN, HOOD RIVER COUNTY, OREGON. THE INITIAL POINT FOR SAID PARTITION IS THE 5/8" X 30" REBAR WITH YELLOW PLASTIC CAP INSCRIBED "HUFFMON PLS 2786" FOUND AT THE NORTHWESTERLY CORNER OF THE SUBJECT PROPERTY AS SET IN COUNTY SURVEY #2007-100. SAID INITIAL POINT BEARS, SOUTH 87°32'38" EAST 1,239.78 FEET AND THENCE SOUTH 29°40'48" WEST 324.71 FEET FROM THE NORTHWEST CORNER OF SAID SECTION 15. SAID CORNER BEING A 1-1/2" PIPE WITH HOOD RIVER COUNTY ALUMINUM CAP AFFIXED. THE PLATTED PROPERTY IS DESCRIBED AS FOLLOWS.

BEGINNING AT THE AFORESAID INITIAL POINT; THENCE SOUTH 60°18'43" EAST 2,359.05 FEET; THENCE SOUTH 29°41'47" WEST 174.98 FEET; THENCE NORTH 60°19'13" WEST 2,359.00 FEET; THENCE NORTH 29°40'48" EAST 175.33 FEET TO THE INITIAL POINT.

CONTAINS 9.48 ACRES.

I HEREBY CERTIFY THAT THIS PLAT IS A TRUE AND EXACT COPY OF THE ORIGINAL PLAT.
Bradley R. Huffmon 8/27/08
 BRADLEY R. HUFFMON DATE

REGISTERED
 PROFESSIONAL
 LAND SURVEYOR

ENGINEER / SURVEYOR:
 TENNESON ENGINEERING CORP.
 409 Lincoln Street,
 The Dalles, Oregon. 97058
 Ph. 541-296-9177
 FAX 541-296-6657

OREGON
 JANUARY 21, 1997
 BRADLEY R. HUFFMON
 2786

EXPIRES: 06/30/2009

SHEET 2 OF 2

CS 2008 061 2

W.O. #12556pla(par 2)