

ALEXANDER DRIVE
(40 FEET WIDE)
S 88°38'33" E 552.07'

15'X20' TELEPHONE R.O.W. EASEMENT
AS PER DOC# 911490

PARCEL 3
5.646 ACRES
(INCLUDES ALEXANDER DR. R.O.W.)

DOC# 851581
BOOK 46, PAGE 473

R.O.W. DEEDS
BOOK 29, PAGE 317
BOOK 29, PAGE 319

LEGEND

- SET 5/8" X 30" IRON ROD WITH YELLOW PLASTIC CAP MARKED "WYEAST LS 2393"
- FOUND IRON PIPE
- CALCULATED POSITION

NARRATIVE

THE PURPOSE OF THIS SURVEY IS TO PARTITION THAT TRACT OF LAND DESCRIBED IN DEED RECORDED AS DOC# 851581. THE APPLICATION TO PARTITION WAS APPROVED UNDER THE MEASURE 37 CLAIMS PROCESS. THE SOUTHEAST QUARTER OF THE SOUTHEAST QUARTER OF SECTION 19 WAS ESTABLISHED BASED ON THE FOUND MONUMENTS AS SHOWN. THE CENTERLINE OF DEE HIGHWAY WAS ESTABLISHED AT MID-POINT BETWEEN THE FOUND RIGHT OF WAY MONUMENTS AS SHOWN. THE RIGHT OF WAY WAS ESTABLISHED 30' EASTERLY OF THE CENTERLINE. DEED DISTANCE WAS HELD TO ESTABLISH THE NORTH, SOUTH AND WEST LINES OF THE DEED EXCEPTION AS DESCRIBED IN DOC# 770246.

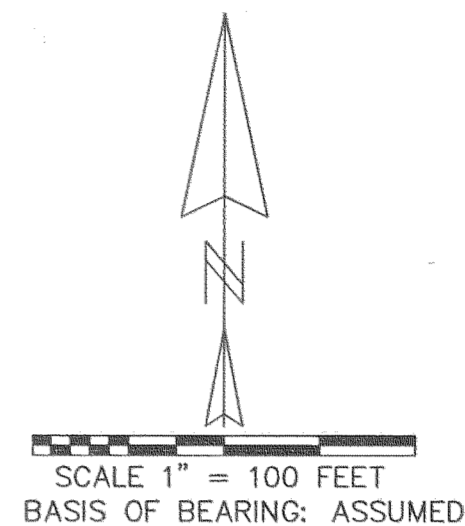

REGISTERED
PROFESSIONAL
LAND SURVEYOR

Kevin Dowd

OREGON
JULY 26, 1989
KEVIN DOWD
2393
RENEW DATE: 12-31-07
DECEMBER 12, 2006

Partition Plat # 200631P

Instrument received on the Dec 19th
day of December 2006
at 3:10 P.M.
Kevin Dowd
Hood River Director of Records
and Assessments

SURVEYOR'S CERTIFICATE:

Kevin Dowd
say that I have correctly surveyed and marked with proper monuments the lands represented on this Partition Plat, the boundaries being described in instrument: DOC# 851581 RECORDED AUGUST 26, 1985 HOOD RIVER COUNTY DEED RECORDS TO ETHEL MAY ELLIOTT

DECLARATION:

We the owner(s) of the land shown herein, hereby declare that this division of land has been made with our free consent and in accordance with our desires.

Ethel May Elliott 12-13-06
OWNER DATE

ACKNOWLEDGMENTS:

This instrument was acknowledged before me on 13 day of Dec 2006

by Barbara Murray
Notary signature

NOTARY PUBLIC - OREGON
COMMISSION No. 404606
My commission expires April 6, 2010

OWNER DATE

This instrument was acknowledged before me on ___ day of ___ 20__

Notary signature

NOTARY PUBLIC - OREGON
COMMISSION No. _____
My commission expires _____

APPROVALS:

I hereby certify that all taxes and assessment due hereon have been fully paid as required by law.
Maureen Murray
Hood River County Director of Budget and Finance

I hereby certify this partition was examined and approved as of this 13th day of December, 2006
Kevin Dowd
Hood River County Surveyor

I hereby certify this partition was examined and approved as of this 19th day of DECEMBER, 2006
Planning File Number #06-187

M. Benedetto
Hood River County Planning Director

LINE	LENGTH	BEARING
L1	40.00	S67°52'14"W
L2	40.00	S67°52'14"W
L3	29.96	S68°08'06"W
L4	29.96	S68°08'06"W
L5	21.65	N21°52'37"W
L6	56.40	N21°55'20"W
L7	21.77	N21°52'37"W
L8	33.31	S88°38'33"E
L9	56.00	S88°38'33"E
L10	20.00	S00°05'58"W
L11	7.32	N89°54'02"W
L12	21.90	S89°33'16"E
L13	37.21	S02°40'40"W
L14	20.01	S02°40'40"W
L15	8.25	S89°22'38"E
L16	38.89	N89°22'38"W

NOTE: L11 DENOTES THE DISTANCE BETWEEN THE CENTERLINE OF THE 10 FOOT UTILITY EASEMENT AND THE CENTERLINE OF THE 30 FEET ROAD AND UTILITY EASEMENT

SUBJECT TO CRYSTAL SPRINGS WATER DISTRICT EASEMENT AS PER DOC# 930282, RECORDED FEBRUARY 1, 1993.

CURVE	DELTA ANGLE	RADIUS	ARC	TANGENT	CHORD	CHORD BEARING
C1	26°26'24"	175.00	80.76	41.11	80.04	N13°07'14"W

HIGHWAY STATION 202 + 19.8 P.O.T.

HIGHWAY STATION 248 + 74.0 P.C.

PARCEL 2
1.50 ACRES

PARCEL 1
1.520 ACRES
(INCLUDES QUINN DR. R.O.W.)

QUINN DRIVE
(40 FEET WIDE)

SOUTHEAST CORNER SECTION 19
FOUND 5/8" IRON ROD IN MONUMENT CASE

WEST 1/4 CORNER SECTION 19
FOUND IRON PIPE/ BRASS DISC

NORTH 1/4 CORNER SECTION 19
FOUND IRON BOLT

EAST 1/4 CORNER SECTION 19
CALCULATED POSITION AS PER CS 78045

SOUTH 1/4 CORNER SECTION 19
FOUND BRASS DISC IN MONUMENT CASE

SOUTHEAST CORNER SECTION 19
FOUND 5/8" IRON ROD IN MONUMENT CASE

NOT TO SCALE

FILED

DEC 27 2006
Kevin Dowd
COUNTY SURVEYOR

PARTITION PLAT

LOCATED IN THE SOUTHEAST QUARTER OF SECTION 19
T1 NORTH, R10 EAST, W.M.
HOOD RIVER COUNTY, OREGON

FOR: **ETHEL ELLIOTT**

Certified to be a true and correct copy of the ORIGINAL
Dept. of Records & Assessment
By Kevin Dowd Deputy

WYEAST SURVEYS
KEVIN DOWD
4399 WOODWORTH DR.
MT HOOD, OR 97041
(541) 352-6065