

CRYSTAL SPRINGS

A REPLAT OF LOTS 2,3,4,5,6 AND 7, BLOCK 8, CASCADE LOCKS
SITUATED IN THE SW 1/4 OF SECTION 12, T2N, R7E, W.M.
CITY OF CASCADE LOCKS, HOOD RIVER COUNTY, OREGON
MARCH 1, 2006

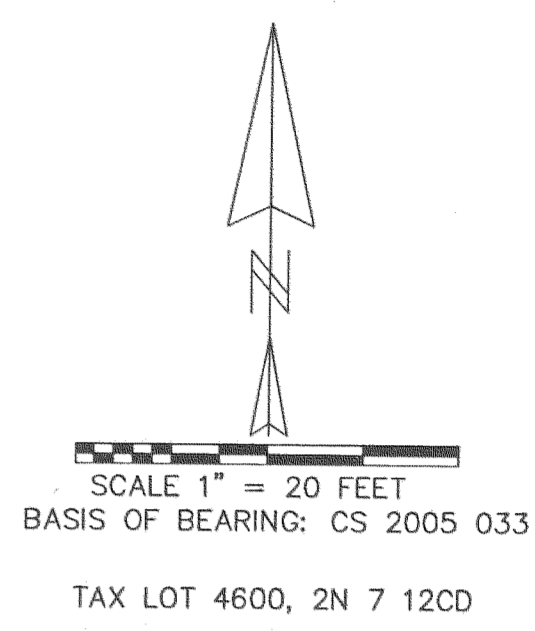
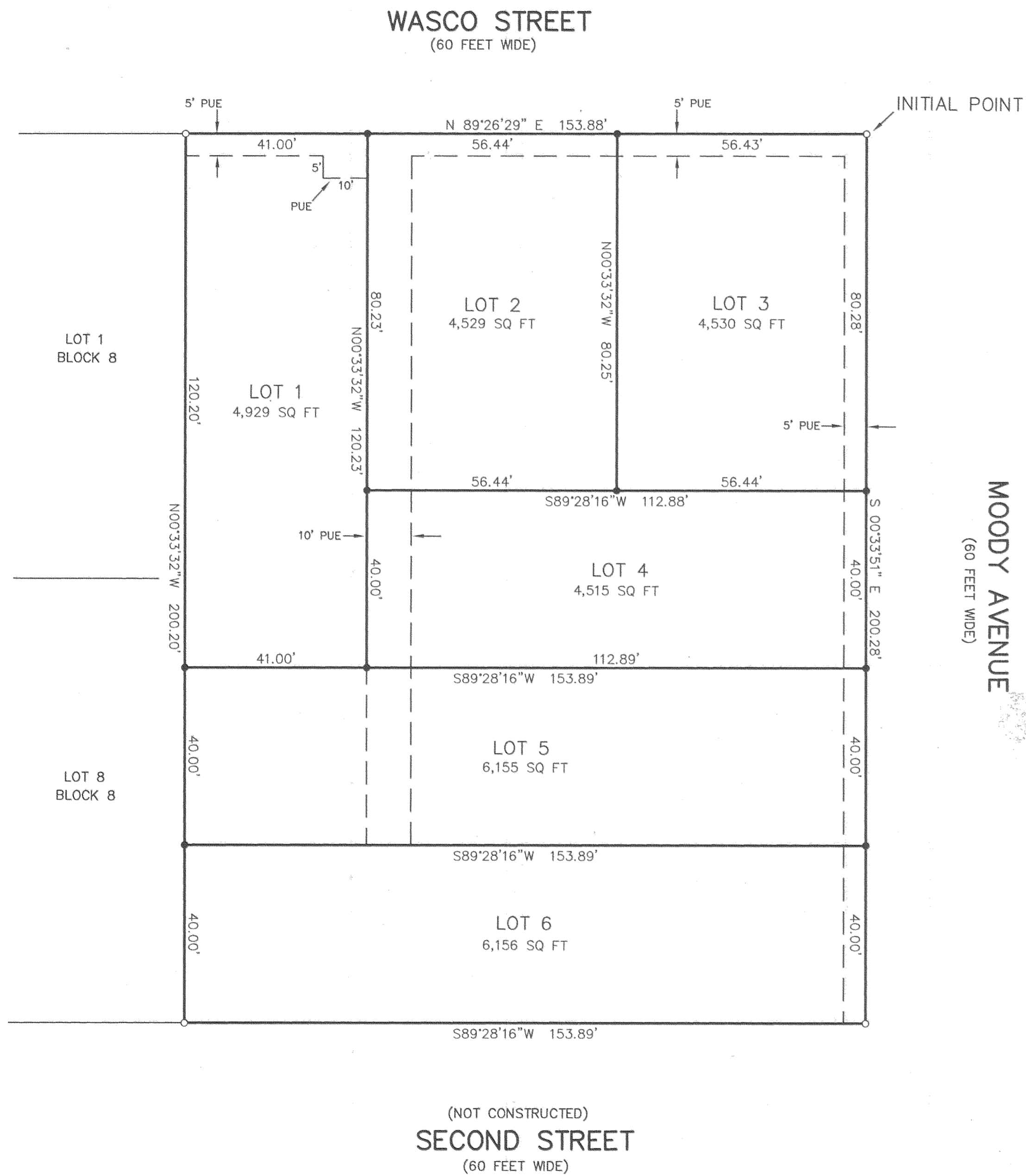

REGISTERED
PROFESSIONAL
LAND SURVEYOR

Kevin Dowd

OREGON
JULY 26, 1989
KEVIN DOWD
2393
RENEW DATE: 12-31-07

LEGEND:

- SET 5/8" X 30" IRON ROD WITH YELLOW PLASTIC CAP MARKED "WYEAST LS 2393"
- FOUND 1/2" IRON ROD AS PER CS 2005 033
- PUE PUBLIC UTILITY EASEMENT
- SQ FT SQUARE FEET

NARRATIVE:

THE PURPOSE OF THIS SURVEY IS TO REPLAT LOTS 2, 3, 4, 5, 6 AND 7, BLOCK 8, "CASCADE LOCKS" INTO 6 LOTS. THE BOUNDARY WAS HELD AS ESTABLISHED IN CS 2005 033.

FILED

MAR 9 2006
Randy J. [Signature]
CLERK

WYEAST SURVEYS
KEVIN DOWD
4399 WOODWORTH DRIVE
MT HOOD, OREGON 97041
(541) 352-6065

SHEET 1 OF 2

CS 2006 021-1

CRYSTAL SPRINGS

A REPLAT OF LOTS 2,3,4,5,6 AND 7, BLOCK 8, CASCADE LOCKS
SITUATED IN THE SW 1/4 OF SECTION 12, T2N, R7E, W.M.
CITY OF CASCADE LOCKS, HOOD RIVER COUNTY, OREGON
MARCH 1, 2006

FILED
RECORDS AND ASSESSMENT
HOOD RIVER CO.
2006 MAR -8 A 9 34

RECORDING INFORMATION
PLAT NUMBER: 20061130
INSTRUMENT RECEIVED ON THE 8th DAY
OF March, 2006 AT 9:34 AM.
Leah Day - Clerk
HOOD RIVER COUNTY CLERK

SURVEYOR'S CERTIFICATE

I, KEVIN DOWD, CERTIFY THAT I HAVE CORRECTLY SURVEYED AND MARKED WITH PROPER MONUMENTS THE LAND REPRESENTED ON THE ANNEXED MAP OF CRYSTAL SPRINGS, SAID LAND BEING DESCRIBED AS FOLLOWS:

LOTS 2, 3, 4, 5, 6 AND 7, BLOCK 8, CASCADE LOCKS,
SITUATED IN THE SOUTHWEST QUARTER OF SECTION 12,
TOWNSHIP 2 NORTH, RANGE 7 EAST OF THE WILLAMETTE MERIDIAN,
IN THE CITY OF CASCADE LOCKS, COUNTY OF HOOD RIVER AND STATE OF OREGON,
BEING MORE PARTICULARLY DESCRIBED AS FOLLOWS:

BEGINNING AT THE INITIAL POINT, BEING THE NORTHEAST CORNER OF SAID LOT 4,
BEING MARKED WITH A 1/2" IRON ROD WITH YELLOW PLASTIC CAP MARKED "WYEAST LS 2393";
THENCE ALONG THE EAST LINE OF SAID BLOCK 8, SOUTH 00°33'51" EAST, A DISTANCE
OF 200.28 FEET TO THE SOUTHEAST CORNER OF SAID BLOCK 8; THENCE ALONG THE SOUTH
LINE OF SAID BLOCK 8, SOUTH 89°28'16" WEST, A DISTANCE OF 153.89 FEET TO THE SOUTHWEST
CORNER OF SAID LOT 7; THENCE ALONG THE WEST LINE OF SAID LOT 7 AND LOT 2,
NORTH 00°33'32" WEST, A DISTANCE OF 200.20 FEET TO THE NORTHWEST CORNER OF SAID LOT 2;
THENCE ALONG THE NORTH LINE OF SAID BLOCK 8, NORTH 89°26'29" EAST, A DISTANCE OF 153.88 FEET
TO THE INITIAL POINT.

APPROVALS

THE ANNEXED MAP OF CRYSTAL SPRINGS WAS EXAMINED AND APPROVED BY ME
THIS 3rd DAY OF March, 2006.

[Signature]
CITY OF CASCADE LOCKS ADMINISTRATOR

THE ANNEXED MAP OF CRYSTAL SPRINGS WAS EXAMINED AND APPROVED BY ME
THIS 6th DAY OF March, 2006.

[Signature]
CITY OF CASCADE LOCKS PUBLIC WORKS DIRECTOR

THE ANNEXED MAP OF CRYSTAL SPRINGS WAS EXAMINED AND APPROVED BY ME
THIS 6th DAY OF March, 2006.

[Signature]
HOOD RIVER COUNTY SURVEYOR

THE ANNEXED MAP OF CRYSTAL SPRINGS WAS EXAMINED AND APPROVED BY ME
THIS 6th DAY OF March, 2006.

[Signature]
CHAIRPERSON, HOOD RIVER COUNTY COMMISSION

THE ANNEXED MAP OF CRYSTAL SPRINGS WAS EXAMINED AND APPROVED BY ME
THIS 6th DAY OF March, 2006.

[Signature]
HOOD RIVER COUNTY COMMISSIONER

THE ANNEXED MAP OF CRYSTAL SPRINGS WAS EXAMINED AND APPROVED BY ME
THIS 6th DAY OF March, 2006.

[Signature]
HOOD RIVER COUNTY COMMISSIONER

THE ANNEXED MAP OF CRYSTAL SPRINGS WAS EXAMINED AND APPROVED BY ME
THIS 6th DAY OF March, 2006.

[Signature]
HOOD RIVER COUNTY COMMISSIONER

THE ANNEXED MAP OF CRYSTAL SPRINGS WAS EXAMINED AND APPROVED BY ME
THIS 6th DAY OF March, 2006.

[Signature]
HOOD RIVER COUNTY COMMISSIONER

DECLARATION

KNOW ALL PEOPLE BY THESE PRESENTS THAT AAA CERTIFIED HOME INSPECTION AND OREGON CUSTOM HOME BUILDERS, LLC, AN OREGON LIMITED LIABILITY COMPANY, AS OWNERS OF THE LAND SHOWN ON THE ANNEXED MAP AND MORE PARTICULARLY DESCRIBED IN THE SURVEYOR'S CERTIFICATE HEREUNTO ATTACHED, HEREBY DEDICATE TO THE PUBLIC FOREVER THE EASEMENTS SHOWN ON SAID MAP, AND DECLARE THE ANNEXED PLAT OF CRYSTAL SPRINGS TO BE A CORRECT PLAT AS LOCATED IN THE SOUTHWEST QUARTER OF SECTION 12, TOWNSHIP 2 NORTH, RANGE 7 EAST OF THE WILLAMETTE MERIDIAN IN THE CITY OF CASCADE LOCKS, COUNTY OF HOOD RIVER AND STATE OF OREGON.

AAA CERTIFIED HOME INSPECTION AND OREGON CUSTOM HOME BUILDERS, LLC,
AN OREGON LIMITED LIABILITY COMPANY

BY: [Signature]
EDWIN R. WAGNER, OWNER

ACKNOWLEDGEMENT

STATE OF OREGON }
COUNTY OF Hood River } SS

THIS IS TO CERTIFY THAT ON THIS 6th DAY OF March, 2006
BEFORE ME A NOTARY PUBLIC IN AND FOR SAID STATE AND COUNTY,
PERSONALLY APPEARED EDWIN R. WAGNER, WHO DID SAY THAT HE IS THE IDENTICAL PERSON
NAMED IN THE FOREGOING INSTRUMENT, AND THAT SAID INSTRUMENT WAS EXECUTED ON
BEHALF OF AAA CERTIFIED HOME INSPECTION AND OREGON CUSTOM HOME BUILDERS, LLC,
AND THE HE EXECUTED SAID INSTRUMENT FREELY AND VOLUNTARILY.

[Signature]
NOTARY SIGNATURE

Hood River Oregon
NOTARY PUBLIC - OREGON

COMMISSION NO. 394328

MY COMMISSION EXPIRES June 27, 2009

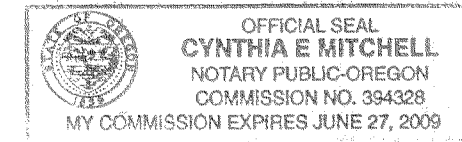

APPROVALS

THE DIRECTOR OF RECORDS AND ASSESSMENTS, AND THE DIRECTOR OF BUDGET, FINANCE AND TAX COLLECTOR, RESPECTIVELY, OF HOOD RIVER COUNTY, OREGON, HEREBY CERTIFY THAT WE HAVE EXAMINED THE ANNEXED MAP OF CRYSTAL SPRINGS, IN THE CITY OF CASCADE LOCKS AND THAT THE NAME ADOPTED FOR SAID PLAT IS A PROPER NAME AND NOT INCLUDED IN ANY OTHER SUBDIVISION IN HOOD RIVER COUNTY, AND FURTHER CERTIFY THAT ALL ASSESSMENTS DUE HEREON HAVE BEEN FULLY PAID AS REQUIRED BY LAW AND WE HEREBY APPROVE SAID PLAT.

[Signature]
HOOD RIVER COUNTY DIRECTOR OF
BUDGET, FINANCE AND TAX COLLECTOR

[Signature] 3/8/2006
HOOD RIVER COUNTY DIRECTOR OF
RECORDS AND ASSESSMENTS

REGISTERED
PROFESSIONAL
LAND SURVEYOR

[Signature]
OREGON
JULY 26, 1989
KEVIN DOWD
2393
RENEW DATE: 12-31-07

WYEAST SURVEYS
KEVIN DOWD
4399 WOODWORTH DRIVE
MT HOOD, OREGON 97041
(541) 352-6065

SHEET 2 OF 2

CS 2006 021.2

FILED

MAR 9 2006
[Signature]
CLERK