

PLAT NUMBER: 20053077
INSTRUMENT RECEIVED ON THE 14 DAY
OF June, 2005 AT 2:03 P.M.

Leah Day
HOOD RIVER COUNTY CLERK

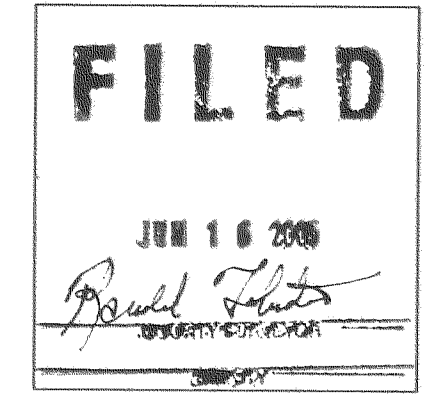

PLAT OF
ELIOT PARK SUBDIVISION, PHASE 2
IN A PORTION OF PARCEL 1, PARTITION PLAT 2003-10P
IN THE NE.1/4 OF THE SW.1/4 OF SECTION 36, TWP.3 N., RANGE 10 E. W.M.
CITY OF HOOD RIVER, HOOD RIVER COUNTY, OREGON

MAY 5, 2005

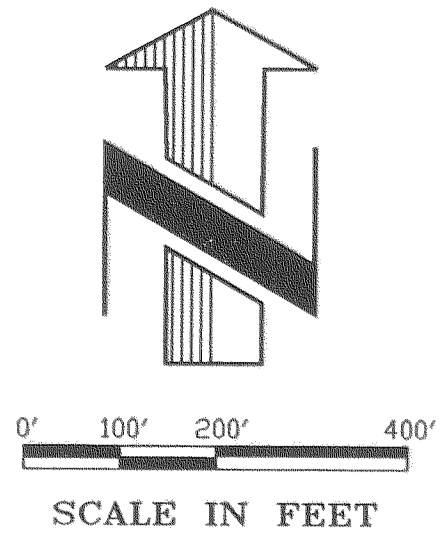

NOTES:

- 1) BEARINGS BASED ON CENTERLINE OF PACIFIC AVENUE AS USED IN SURVEY REFERENCES #2, #3, #4, #6 AND #8.
- 2) PROPERTY SUBJECT TO TERMS AND CONDITIONS OF RURAL WATER APPLICATION AND ANNEXATION AGREEMENT RECORDED MARCH 7, 1984 AT FILE# 840369.
- 3) PHASE 2 OF THIS SUBDIVISION HAS BEEN FINAL PLATTED PER THE CONDITIONS OF APPROVAL FOR PHASE 3 OF THE CITY OF HOOD RIVER PLANNING COMMISSION PRELIMINARY APPROVAL OF THE ELIOT PARK SUBDIVISION DATED MARCH 24, 2003.

LEGEND:

- SET 5/8" X 30" REBAR WITH YELLOW PLASTIC CAP, INSCRIBED "B BESEDA LS 50800"
- FOUND MONUMENTS, AS NOTED.
- CALCULATED CORNERS, NOT SET.
- SET HUB & TACK.
- SET P.K. NAIL OR AS NOTED.
- ◆ SET 5/8" X 30" REBAR WITH 1-1/2" ALUM. CAP, INSCRIBED "B BESEDA, LS 50800"
- x- EXISTING FENCE LINE.

LAND INFORMATION:

27.21 ACRES (TOTAL)
4.12 ACRES (PHASE 2)
TAX LOT 200
ASSESSOR'S MAP 3N-10E-36C
19 LOTS (PHASE 2)
ZONE: R-2

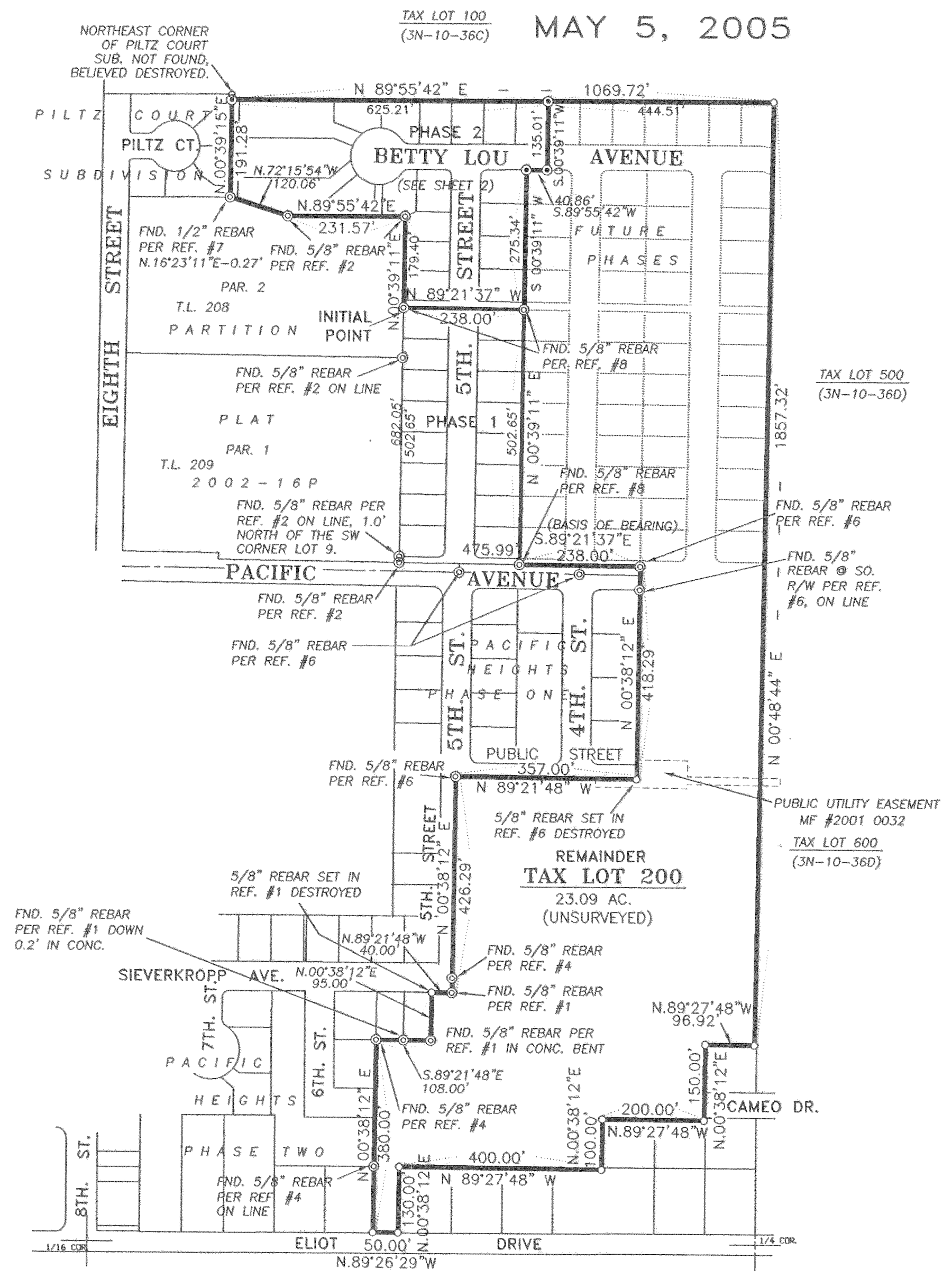

OWNER:

SIEVERKROPP ORCHARDS, INC.
2470 PAASCH ROAD
HOOD RIVER, OREGON. 97031
PH. (541) 490-1273
THOMAS K. SIEVERKROPP, PRESIDENT

REFERENCES:

- 1) PARTITION PLAT 2003-10P FOR SIEVERKROPP ORCHARDS, INC. BY TENNESON ENGINEERING CORP. W.O. #10693, APRIL 2003 RECORDED APRIL 30, 2003 C.S. #2003 024
- 2) PARTITION PLAT 2002-16P FOR SIEVERKROPP ORCHARDS, INC. BY TERRA SURVEYING, INC. RECORDED JULY 11, 2002 C.S. #2002 049
- 3) PARTITION PLAT 99-14 FOR DAVE NELSON (OWNER SIEVERKROPP ORCHARDS, INC.) BY WYEAST SURVEYS, RECORDED AUGUST 9, 1999 C.S. #99069
- 4) PLAT OF PACIFIC HEIGHTS, PHASE TWO BY WYEAST SURVEYS RECORDED AUGUST 29, 1999 FILE #20013680 C.S. #2001 068
- 5) PLAT OF PILTZ COURT SUBDIVISION BY TENNESON ENGINEERING CORP. W.O. #8319, RECORDED SEPTEMBER 23, 1998 FILE #984228 C.S. #98074
- 6) PLAT OF PACIFIC HEIGHTS, PHASE ONE BY WYEAST SURVEYS, RECORDED MAY 24, 2000, FILE #20001856 C.S. #2000 45
- 7) SURVEY IN THE NE.1/4 OF THE SW.1/4, SEC. 36, T.3N. R.10E. W.M. BY TENNESON ENGINEERING CORP. W.O. #5401, SEPTEMBER, 1977 C.S. #78025
- 8) PLAT OF ELIOT PARK SUB. PHASE 1 BY TENNESON ENGINEERING CORP. W.O. #10627, MAY 11, 2004 RECORDED DECEMBER 21, 2004 FILE #20045829 C.S. #2004 084 (12/29/04)

ENGINEER / SURVEYOR:

TENNESON ENGINEERING CORP.
409 Lincoln Street,
The Dalles, Oregon. 97058
Ph. 541-296-9177
FAX 541-296-6657

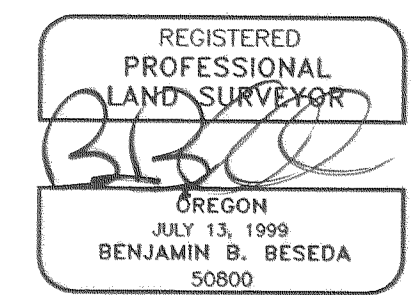

EXPIRES: 12/31/05

FILED
 HOOD RIVER CO.
 JUN 14 2 03 PM '05

RECORDING INFORMATION:

PLAT NUMBER: 20053077
 INSTRUMENT RECEIVED ON THE 14 DAY
 OF June, 2005 AT 2:03 P.M.

Leah Day
 HOOD RIVER COUNTY CLERK

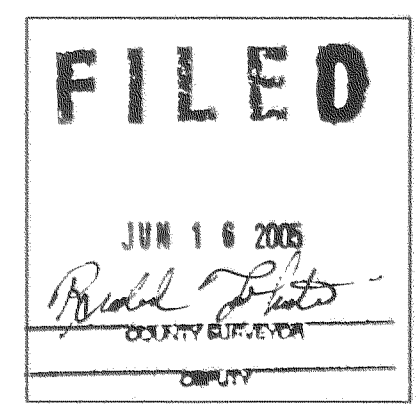

OWNER:
 SIEVERKROPP ORCHARDS, INC.
 2470 PAASCH ROAD
 HOOD RIVER, OREGON. 97031
 PH. (541) 490-1273
 THOMAS K. SIEVERKROPP, PRESIDENT

PLAT OF
ELIOT PARK SUBDIVISION, PHASE 2
 IN A PORTION OF PARCEL 1, PARTITION PLAT 2003-10P
 IN THE NE.1/4 OF THE SW.1/4 OF SECTION 36, TWP.3 N., RANGE 10 E. W.M.
 CITY OF HOOD RIVER, HOOD RIVER COUNTY, OREGON
 MAY 5, 2005

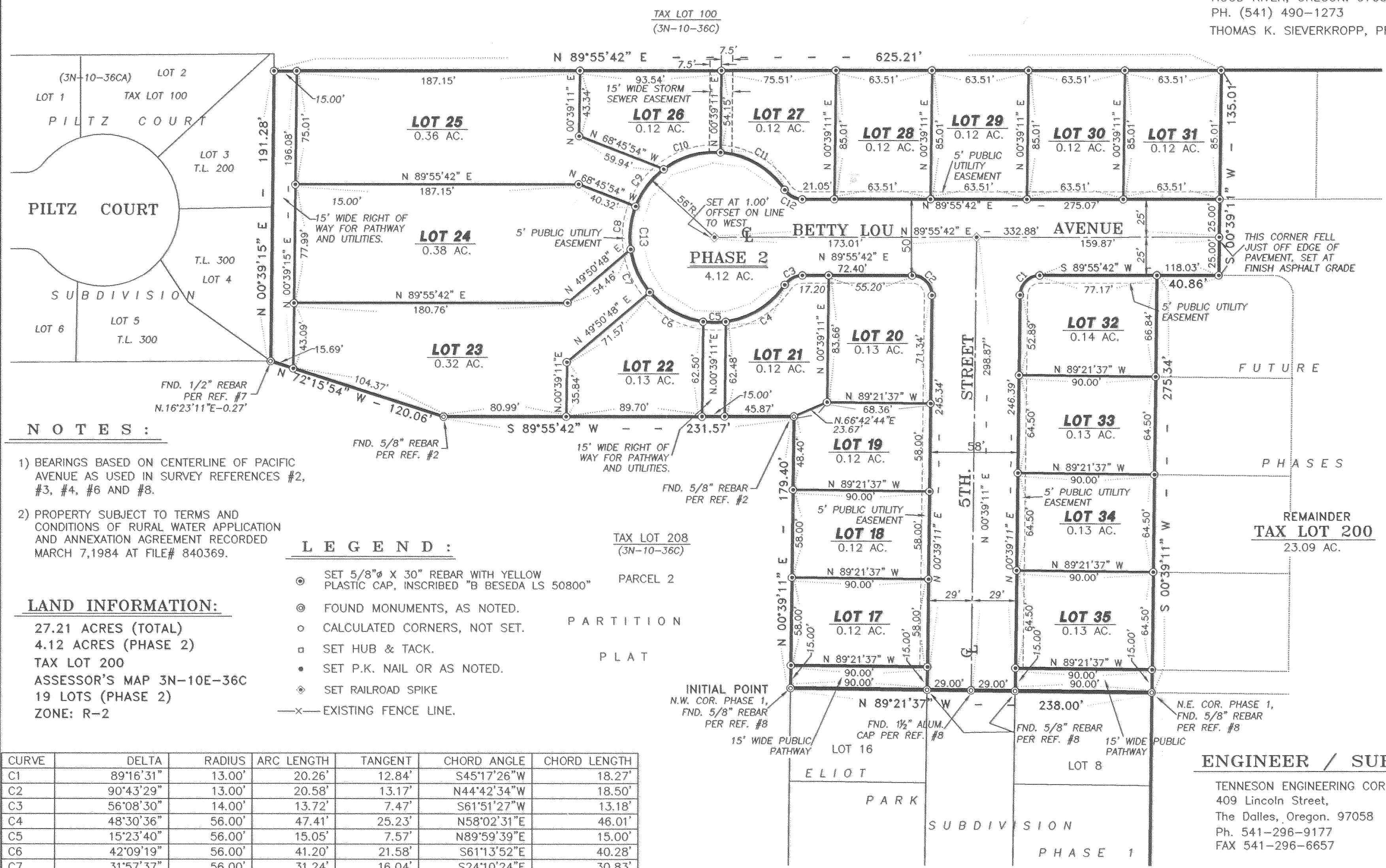
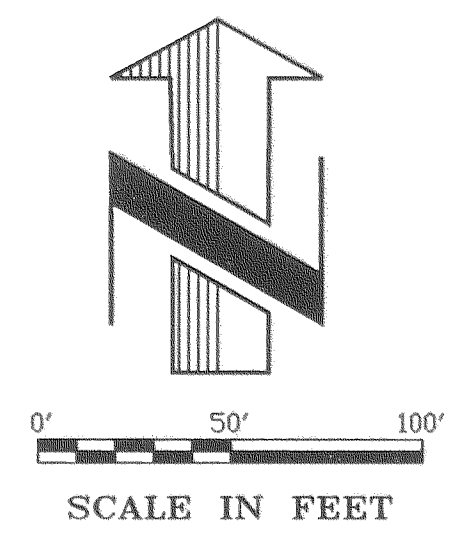

NOTES:

- BEARINGS BASED ON CENTERLINE OF PACIFIC AVENUE AS USED IN SURVEY REFERENCES #2, #3, #4, #6 AND #8.
- PROPERTY SUBJECT TO TERMS AND CONDITIONS OF RURAL WATER APPLICATION AND ANNEXATION AGREEMENT RECORDED MARCH 7, 1984 AT FILE# 840369.

LEGEND:

- SET 5/8" X 30" REBAR WITH YELLOW PLASTIC CAP, INSCRIBED "B BESEDA LS 50800" PARCEL 2
- FOUND MONUMENTS, AS NOTED.
- CALCULATED CORNERS, NOT SET.
- SET HUB & TACK.
- SET P.K. NAIL OR AS NOTED.
- SET RAILROAD SPIKE
- EXISTING FENCE LINE.

LAND INFORMATION:

27.21 ACRES (TOTAL)
 4.12 ACRES (PHASE 2)
 TAX LOT 200
 ASSESSOR'S MAP 3N-10E-36C
 19 LOTS (PHASE 2)
 ZONE: R-2

CURVE	DELTA	RADIUS	ARC LENGTH	TANGENT	CHORD ANGLE	CHORD LENGTH
C1	89°16'31"	13.00'	20.26'	12.84'	S45°17'26"W	18.27'
C2	90°43'29"	13.00'	20.58'	13.17'	N44°42'34"W	18.50'
C3	56°08'30"	14.00'	13.72'	7.47'	S61°51'27"W	13.18'
C4	48°30'36"	56.00'	47.41'	25.23'	N58°02'31"E	46.01'
C5	15°23'40"	56.00'	15.05'	7.57'	N89°59'39"E	15.00'
C6	42°09'19"	56.00'	41.20'	21.58'	S61°13'52"E	40.28'
C7	31°57'37"	56.00'	31.24'	16.04'	S24°10'24"E	30.83'
C8	29°25'41"	56.00'	28.76'	14.71'	S6°31'15"W	28.45'
C9	31°57'37"	56.00'	31.24'	16.04'	S37°12'54"W	30.83'
C10	40°53'27"	56.00'	39.97'	20.88'	S73°38'26"W	39.12'
C11	51°59'02"	56.00'	50.81'	27.30'	N59°55'19"W	49.08'
C12	56°08'30"	14.00'	13.72'	7.47'	S62°00'03"E	13.18'

REFERENCES:

- PARTITION PLAT 2003-10P FOR SIEVERKROPP ORCHARDS, INC. BY TENNESON ENGINEERING CORP. W.O. #10693, APRIL 2003 RECORDED APRIL 30, 2003 C.S. 2003 024
- PARTITION PLAT 2002-16P FOR SIEVERKROPP ORCHARDS, INC. BY TERRA SURVEYING, INC. RECORDED JULY 11, 2002 C.S. #2002 049
- PARTITION PLAT 99-14 FOR DAVE NELSON (OWNER SIEVERKROPP ORCHARDS, INC.) BY WYEST SURVEYS, RECORDED AUGUST 9, 1999 C.S. #99069
- PLAT OF PACIFIC HEIGHTS, PHASE TWO BY WYEST SURVEYS RECORDED AUGUST 29, 1999 FILE #20013680 C.S. #2001 068
- PLAT OF PILTZ COURT SUBDIVISION BY TENNESON ENGINEERING CORP. W.O. #8319, RECORDED SEPTEMBER 23, 1998 FILE #984228 C.S. #98074
- PLAT OF PACIFIC HEIGHTS, PHASE ONE BY WYEST SURVEYS, RECORDED MAY 24, 2000, FILE #20001856 C.S. #2000 45
- SURVEY IN THE NE.1/4 OF THE SW.1/4, SEC. 36, T.3N. R.10E. W.M. BY TENNESON ENGINEERING CORP. W.O. #5401, SEPTEMBER, 1977 C.S. #78025
- PLAT OF ELIOT PARK SUB. PHASE 1 BY TENNESON ENGINEERING CORP. W.O. #10627, MAY 11, 2004 RECORDED DECEMBER 21, 2004 FILE #20045829 CS. #2004 084 (12/29/04)

ENGINEER / SURVEYOR:

TENNESON ENGINEERING CORP.
 409 Lincoln Street,
 The Dalles, Oregon. 97058
 Ph. 541-296-9177
 FAX 541-296-6657

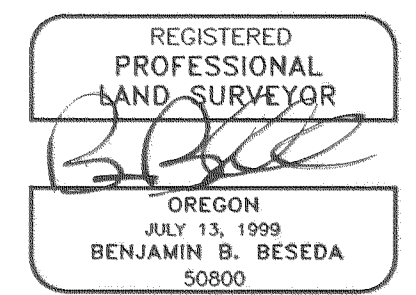

EXPIRES: 12/31/05

OWNER:

SIEVERKROPP ORCHARDS, INC.
2470 PAASCH ROAD
HOOD RIVER, OREGON. 97031
PH. (541) 490-1273
THOMAS K. SIEVERKROPP, PRESIDENT

PLAT OF
ELIOT PARK SUBDIVISION, PHASE 2
IN A PORTION OF PARCEL 1, PARTITION PLAT 2003-10P
IN THE NE.1/4 OF THE SW.1/4 OF SECTION 36, TWP.3 N., RANGE 10 E. W.M.
CITY OF HOOD RIVER, HOOD RIVER COUNTY, OREGON
MAY 5, 2005

FILED
HOOD RIVER CO.
JUN 14 2 03 PM '05
FILED
JUN 16 2005
ROCHELLE T. JONES
COUNTY CLERK

RECORDING INFORMATION:

PLAT NUMBER: 20053077
INSTRUMENT RECEIVED ON THE 14 DAY
OF June, 2005 AT 2:03 P.M.
Leah Day
HOOD RIVER COUNTY CLERK

APPROVALS:

I, HEREBY CERTIFY THAT ALL TAXES AND ASSESSMENTS DUE HEREON HAVE BEEN PAID AS REQUIRED BY LAW AND HEREBY APPROVE THE PLAT OF "ELIOT PARK SUBDIVISION, PHASE 2".

Candace Horvath 6/14/05
Hood River County Director of Budget and Finance Date

I, HEREBY CERTIFY THAT I HAVE EXAMINED THE PLAT OF "ELIOT PARK SUBDIVISION, PHASE 2" AND THAT THE NAME ADOPTED TO SAID PLAT IS A PROPER NAME AND NOT INCLUDED IN ANY OTHER SUBDIVISION IN HOOD RIVER COUNTY AND HEREBY APPROVE SAID PLAT.

Sandra E Berry 6/14/05
Hood River County Director of Records and Assessments. Date

DEDICATION:

I, THOMAS K. SIEVERKROPP, PRESIDENT OF SIEVERKROPP ORCHARDS, INC. AS OWNER OF THE LAND SHOWN ON THE PLAT HEREUNTO ATTACHED AND MORE PARTICULARLY DESCRIBED IN THE SURVEYOR'S CERTIFICATE, ALSO HEREUNTO ATTACHED, DEDICATE TO THE PUBLIC FOREVER ALL STREETS AND PATHWAY/UTILITY CORRIDORS SHOWN ON SUCH PLAT AND DECLARE THE PLAT OF "ELIOT PARK SUBDIVISION, PHASE 2" TO BE A CORRECT PLAT AS LOCATED IN THE SOUTHWEST 1/4, SECTION 36, TOWNSHIP 3 NORTH, RANGE 10 EAST, W.M., HOOD RIVER COUNTY, OREGON.

Thomas K Sieverkropp
THOMAS K. SIEVERKROPP, PRESIDENT OF SIEVERKROPP ORCHARDS, INC.

ACKNOWLEDGEMENT:

ON THIS 6th DAY OF May, 2005,
BEFORE ME A NOTARY PUBLIC FOR THE STATE OF OREGON, PERSONALLY APPEARED THOMAS K. SIEVERKROPP, PRESIDENT OF SIEVERKROPP ORCHARDS, INC. KNOWN TO ME PERSONALLY, BEING FIRST DULY SWORN, SAID THAT HE DID ACKNOWLEDGE THIS INSTRUMENT OF HIS FREE AND VOLUNTARY ACT.

Denise Endow
Signature

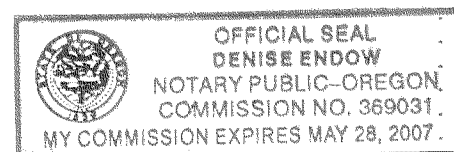

DENISE ENDOW
Printed Name
Notary Public for the State of Oregon,
County of HOOD RIVER
Commission Number 369031
My commission expires May 28, 2007

NARRATIVE:

THE PURPOSE OF THIS SURVEY WAS TO MONUMENT THE EXTERIOR BOUNDARY, ROADWAYS, AND LOTS THEREIN OF THE PLAT OF ELIOT PARK SUBDIVISION, PHASE 2. THE PROPERTY LIES IN THE NORTHEAST 1/4 OF THE SOUTHWEST 1/4 OF SECTION 36, TOWNSHIP 3 NORTH, RANGE 10 EAST, WILLAMETTE MERIDIAN. THE SUBJECT PROPERTY IS A PORTION OF THE REMAINDER PARTITION PARCEL FROM THREE PRIOR PARTITIONS AND PHASE 1 OF THE ELIOT PARK SUBDIVISION. BOUNDARY ESTABLISHMENT WAS IDENTICAL AS ESTABLISHED IN PHASE 1 OF ELIOT PARK. THIS PLAT REPRESENTS PHASE 2 OF THE SUBDIVISION. EXISTING MONUMENTS WERE FOUND ON THE BOUNDARY OF PHASE 2 ARE SHOWN. BASIS OF BEARING IN THIS SURVEY IS AS PER PHASE 1, WHICH IS OREGON NORTH ZONE GRID, NAD 1983. NO BOUNDARY DISCREPANCIES OR ENCROACHMENTS ARE NOTED WITHIN PHASE 2. THE REMAINDER PROPERTY IS UNSURVEYED.

WITH RESOLUTION OF THE BOUNDARY OF PHASE 2, THE INDIVIDUAL LOTS AND STREETS WERE LAID OUT IN ACCORDANCE WITH THE APPROVED PRELIMINARY PLAT OF THE SUBDIVISION.

SET AS SHOWN ON THE SURVEY: 5/8"x 30" REBAR WITH YELLOW PLASTIC CAP INSCRIBED "B BESEDA, LS 50800".

SURVEYOR'S CERTIFICATE:

I, BENJAMIN B. BESEDA, REGISTERED LAND SURVEYOR #50800 IN THE STATE OF OREGON, BEING FIRST DULY SWORN, DEPOSE AND SAY THAT I HAVE CORRECTLY SURVEYED AND MARKED WITH LEGAL MONUMENTS, ACCORDING TO ORS CHAPTER 92 AND THE CITY OF HOOD RIVER LAND USE DEVELOPMENT ORDINANCE, THE LAND REPRESENTED ON THE PLAT OF ELIOT PARK SUBDIVISION, PHASE 2, LYING IN A PORTION OF PARCEL 1 OF PARTITION PLAT 2003-10P IN THE NORTHEAST 1/4 OF THE SOUTHWEST 1/4 OF SECTION 36, TOWNSHIP 3 NORTH, RANGE 10 EAST, WILLAMETTE MERIDIAN, CITY OF HOOD RIVER, HOOD RIVER COUNTY, OREGON. THE INITIAL POINT FOR SAID PLAT IS THE 5/8"x 30" REBAR WITH YELLOW PLASTIC CAP INSCRIBED "B BESEDA, LS 50800" FOUND AT THE SOUTHWEST CORNER OF SAID PHASE 2, SAID INITIAL POINT BEING THE NORTHWEST CORNER OF ELIOT PARK SUBDIVISION, PHASE 1. THE PLATTED PROPERTY IS DESCRIBED AS FOLLOWS.

BEGINNING AT THE AFORESAID INITIAL POINT; THENCE NORTH 00°39'11" EAST 179.40 FEET; THENCE SOUTH 89°55'42" WEST 231.57 FEET; THENCE NORTH 72°15'54" WEST 120.06 FEET; THENCE NORTH 00°39'15" EAST 191.28 FEET; THENCE NORTH 89°55'42" EAST 625.21 FEET; THENCE SOUTH 00°39'11" WEST 135.01 FEET; THENCE SOUTH 89°55'42" WEST 40.86 FEET; THENCE SOUTH 00°39'11" WEST 275.34 FEET; THENCE NORTH 89°21'37" WEST 238.00 FEET TO THE INITIAL POINT.

CONTAINS 4.12 ACRES, MORE OR LESS.

SUBJECT TO ALL EASEMENTS, AGREEMENTS, AND RIGHTS-OF-WAY OF RECORD.

APPROVALS:

WE, THE UNDERSIGNED, SAY THAT WE HAVE EXAMINED THE PLAT OF "ELIOT PARK SUBDIVISION, PHASE 2" IN THE CITY OF HOOD RIVER, HOOD RIVER COUNTY, OREGON AND HEREBY APPROVE SAID PLAT.

David H Bab 6/13/05
City Public Works & Engineering Director Date
Cynthia Walbridge 6/13/05
City Planning Director Date
Rochelle Jones 5-9-05
Hood River County Surveyor Date
Prof. Seimola 5/13/05
County Board of Commissioners Chairman Date
David H 6/13/05
Hood River City Mayor Date
Jean M. Hadley 6-13-05
Hood River City Recorder Date

ENGINEER / SURVEYOR:

TENNESON ENGINEERING CORP.
409 Lincoln Street,
The Dalles, Oregon. 97058
Ph. 541-296-9177
FAX 541-296-6657

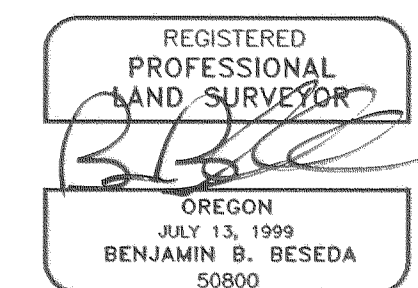

EXPIRES: 12/31/05