

FILED  
RECORDS AND ASSESSMENT  
HOOD RIVER CO.  
FEB 19 10 03 AM '04

# PLAT OF COLUMBIA CREST SUBDIVISION

TAX LOT 200, MAP 3N-10-35BC  
IN GOVERNMENT LOT 6 OF SECTION 35,  
TWP. 3 N., RANGE 10 E. W.M.  
HOOD RIVER, HOOD RIVER COUNTY, OREGON  
FEBRUARY 6, 2004

**RECORDING INFORMATION:**  
PLAT NUMBER: 20040629  
INSTRUMENT RECEIVED ON THE 19<sup>th</sup> DAY  
OF February, 2004 AT 10:03 A.M.  
Cindy J. Jahn - Deputy Clerk  
HOOD RIVER COUNTY CLERK

**ENGINEER / SURVEYOR:**  
TENNESON ENGINEERING CORP.  
409 Lincoln Street,  
The Dalles, Oregon. 97058  
Ph. 541-296-9177  
FAX 541-296-6657

**NOTES:**

- 1) BEARINGS BASED ON PLAT OF "RAND ADDITION" BETWEEN D.L.C. MONUMENTS TIED IN MAY STREET.
- 2) CURRENT DEED (MF 20036174) FOR THE SUBJECT PROPERTY CONTAINS A RESERVATION AND TWO EASEMENTS. THE RESERVATION IS TO HOOD RIVER SPRING WATER CO. FOR WATER FROM A WELL AND RIGHT OF WAY FOR A PIPELINE (BK. K, PG. 627). THE EASEMENTS BK. G, PG. 133 AND BK. 4, PG. 240 ARE IDENTICAL AND ARE TO THE HOOD RIVER ELECTRIC LIGHT, POWER AND WATER CO. FOR RIGHT OF WAY FOR PIPELINE. THESE ENTITIES ARE BELIEVED TO BE NO LONGER IN OPERATION AND THE WELLS AND PIPELINES DESTROYED OR ABANDONED. NO EVIDENCE OF THEIR EXISTENCE OR USE REMAINS UPON THE SUBJECT PROPERTY.

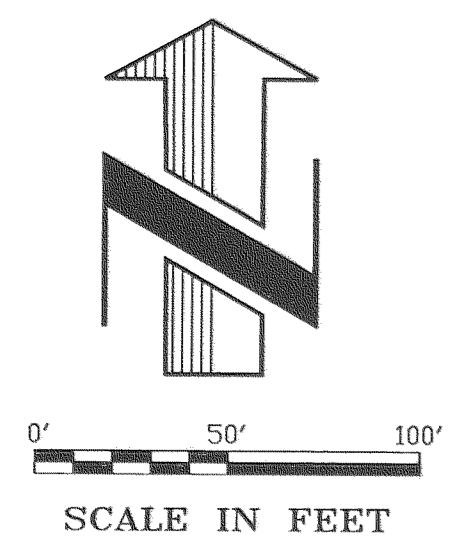

**REFERENCES:**

- 1) PLAT OF RAND ADDITION BY TERRA SURVEYING CS #95048
- 2) PLAT OF ORDWAY AND COHOE PROPERTY BY MART C. PERKINS, P.E., FEB 18, 1958, CS 747.
- 3) DEED RECORDS OF HOOD RIVER COUNTY: BOOK 39, PAGE 511; BOOK 39, PAGE 513; BOOK 39, PAGE 480; MF #970373

TAX LOT 500  
(3N-10-35BC)

TAX LOT 300  
(3N-10-35BC)

APPROXIMATE TOP AND BOTTOM EXTENTS OF ROCK FENCE EXISTING AT TIME OF INITIAL TOPOGRAPHIC MAPPING OF SITE. ROCK FENCE MAY HAVE BEEN IMPACTED BY CONSTRUCTION ACTIVITIES. FENCE POST IN ROCK FENCE CALLED IN DEED NOT FOUND.

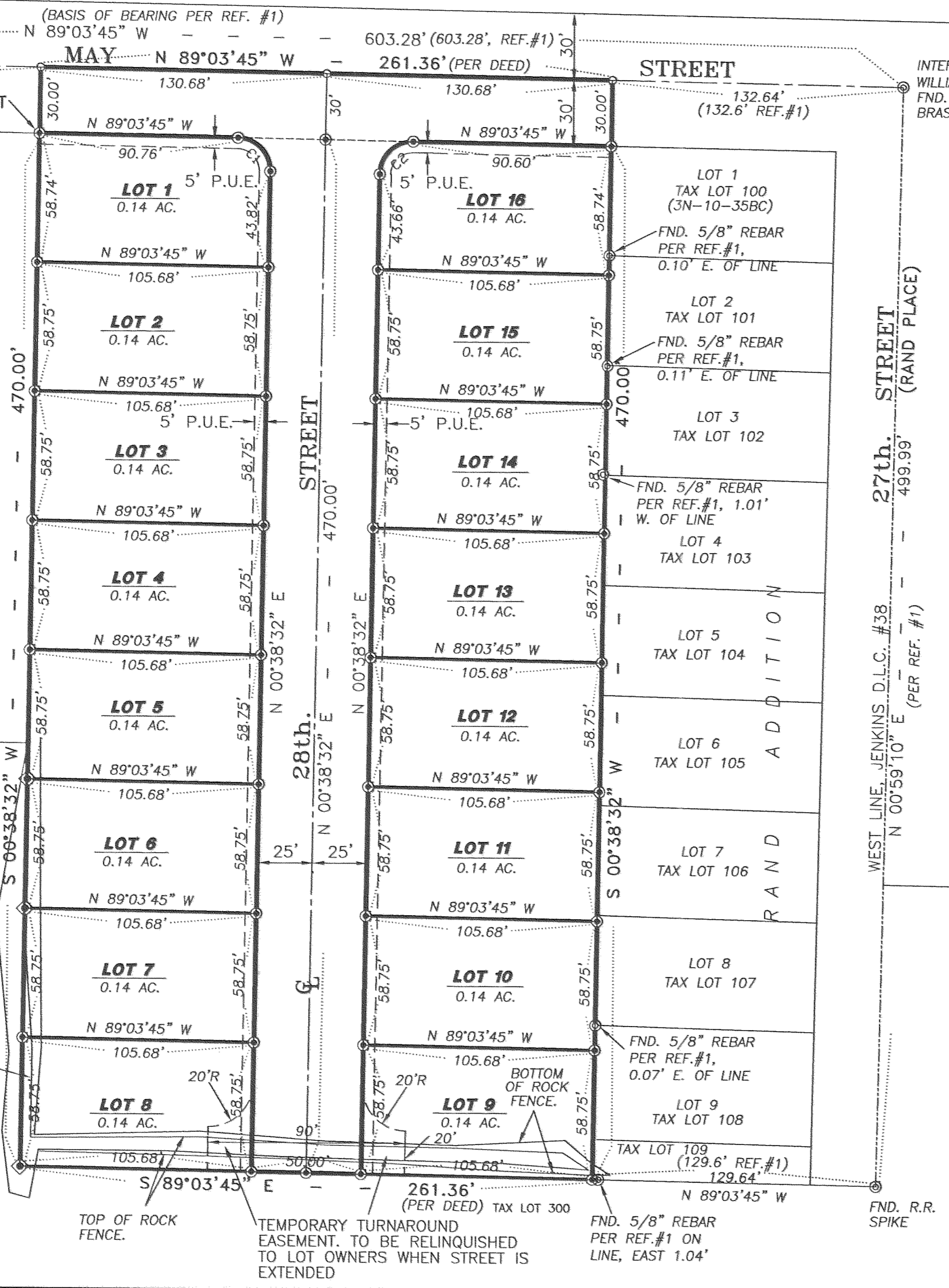

**LAND INFORMATION:**

2.82 ACRES  
TAX LOT 200  
ASSESSOR'S MAP 3N-10-35BC  
16 LOTS  
ZONE: R-2

**LAND OWNER:**

COLUMBIA RIVER ELECTRIC, INC.  
MARK E. McCAVIC, PRESIDENT  
KRISTI McCAVIC, VICE PRESIDENT  
5277 CHERRY HEIGHTS ROAD  
THE DALLES, OR. 97058  
PH. (541) 298-2244

**LEGEND:**

- ⊙ SET 5/8" X 30" REBAR WITH YELLOW PLASTIC CAP, INSCRIBED "B BESEDA, LS 50800"
- ⊙ FOUND MONUMENTS, AS NOTED.
- CALCULATED CORNERS, NOT SET.
- SET HUB & TACK.
- SET P.K. NAIL OR AS NOTED.
- ◆ SET BRASS SCREW WITH WASHER "LS 50800"
- x- EXISTING FENCE LINE.

CURVE	DELTA	RADIUS	ARC LENGTH	TANGENT	CHORD ANGLE	CHORD LENGTH
C1	89°42'17"	15.00'	23.48'	14.92'	N 44°12'36" W	21.16'
C2	90°17'43"	15.00'	23.64'	15.08'	S 45°47'24" W	21.27'

**FILED**

MAR 3 2004  
Benjamin B. Beseda  
REGISTERED PROFESSIONAL LAND SURVEYOR

REGISTERED PROFESSIONAL LAND SURVEYOR  
Benjamin B. Beseda  
OREGON  
JULY 13, 1999  
BENJAMIN B. BESEDA  
50800

FEB 19 2004  
Certified to be a true and correct copy of the ORIGINAL.  
Deputy Registrar & Assessment  
by [Signature] Deputy

EXPIRES: 12/31/05

FEB 19 10 03 AM '04

# PLAT OF COLUMBIA CREST SUBDIVISION

TAX LOT 200, MAP 3N-10-35BC  
IN GOVERNMENT LOT 6 OF SECTION 35,  
TWP. 3 N., RANGE 10 E. W.M.

HOOD RIVER, HOOD RIVER COUNTY, OREGON  
FEBRUARY 6, 2004

### RECORDING INFORMATION:

PLAT NUMBER: 20040629  
INSTRUMENT RECEIVED ON THE 19<sup>th</sup> DAY  
OF February, 2004 AT 10:03 A.M.

Cindy Judah - Deputy Clerk  
HOOD RIVER COUNTY CLERK

### LAND OWNER:

COLUMBIA RIVER ELECTRIC, INC.  
MARK E. McCAVIC, PRESIDENT  
KRISTI McCAVIC, VICE PRESIDENT  
5277 CHERRY HEIGHTS ROAD  
THE DALLES, OR. 97058  
PH. (541) 298-2244

### APPROVALS:

I, HEREBY CERTIFY THAT ALL TAXES AND ASSESSMENTS DUE HEREON  
HAVE BEEN PAID AS REQUIRED BY LAW AND HEREBY APPROVE THE  
PLAT OF "COLUMBIA CREST SUBDIVISION"

Douglas Brown 2/19/04  
Hood River County Director of Budget and Finance Date

I, HEREBY CERTIFY THAT I HAVE EXAMINED THE PLAT OF  
"COLUMBIA CREST SUBDIVISION" AND THAT THE NAME ADOPTED  
TO SAID PLAT IS A PROPER NAME AND NOT INCLUDED IN ANY  
OTHER SUBDIVISION IN HOOD RIVER COUNTY AND HEREBY  
APPROVE SAID PLAT.

Sandra E Berry 2/19/04  
Hood River County Director of  
Records and Assessments. Date

### DEDICATION:

WE, MARK E. McCAVIC, PRESIDENT AND KRISTI McCAVIC, VICE PRESIDENT OF  
COLUMBIA RIVER ELECTRIC, INC. AS OWNERS OF THE LAND SHOWN ON THE  
PLAT HEREUNTO ATTACHED AND MORE PARTICULAR DESCRIBED IN THE  
SURVEYOR'S CERTIFICATE ALSO HEREUNTO ATTACHED, DEDICATE TO THE  
PUBLIC FOREVER ALL STREETS AND EASEMENTS SHOWN ON SUCH PLAT AND  
THAT WE DECLARE THE PLAT OF "COLUMBIA CREST SUBDIVISION" TO BE A  
CORRECT PLAT AS LOCATED IN SECTION 35, TOWNSHIP 3 NORTH, RANGE 10  
EAST, W.M., HOOD RIVER COUNTY, OREGON.

Mark E. McCavic 2-6-04  
MARK E. McCAVIC, PRESIDENT DATE

Kristi McCavic 2-6-04  
KRISTI McCAVIC, VICE PRESIDENT DATE

### ACKNOWLEDGEMENT:

ON THIS 6<sup>th</sup> DAY OF FEBRUARY, 2004,  
BEFORE ME A NOTARY PUBLIC FOR THE STATE OF OREGON, PERSONALLY  
APPEARED MARK E. McCAVIC, PRESIDENT AND KRISTI McCAVIC, VICE PRESIDENT  
OF COLUMBIA RIVER ELECTRIC, INC., KNOWN TO ME PERSONALLY, BEING FIRST  
DULY SWORN, SAY THAT THEY DID ACKNOWLEDGE THIS INSTRUMENT OF THEIR  
FREE AND VOLUNTARY ACT.

Darrin O. Eckman  
Signature

DARRIN O. ECKMAN  
Printed Name  
Notary Public for the State of Oregon,

County of Wasco  
Commission Number 339442  
My commission expires 10.16.04



### NARRATIVE:

THE PURPOSE OF THIS SURVEY WAS TO MONUMENT THE EXTERIOR BOUNDARY, ROADWAY, AND LOTS THEREIN OF THE  
PLAT OF COLUMBIA CREST SUBDIVISION. THE PROPERTY LIES IN GOVERNMENT LOT 6 OF SECTION 35. IN THE FIELD,  
CONTROLLING MONUMENTS WERE TIED ALONG THE CENTERLINE OF MAY STREET, WHICH ARE CORNERS OF THE WILLIAM  
JENKINS DLC #38, AND A RAILROAD SPIKE ON THE WEST LINE OF THE JENKINS DLC. ALSO IN THE FIELD,  
MONUMENTS WERE TIED ALONG THE EAST LINE OF THE SUBJECT PROPERTY FROM THE PLAT OF RAND ADDITION.  
SURVEY REFERENCES FOR THIS SUBDIVISION INCLUDE THE PLAT OF RAND ADDITION, COMPLETED IN 1995 BY TERRA  
SURVEY, ADJOINING TO THE EAST, AND A PLAT OF THE ORDWAY AND COHOE PROPERTY, COMPLETED IN 1958 BY  
MART PERKINS, P.E. STUDY OF THE DEED FOR THE SUBJECT PROPERTY LED TO THE CONCLUSION THAT THE BEARING  
AND DISTANCE CALLS WITHIN THE DEED COULD NOT BE RECONCILED TO FIT WITH THE CALLS TO THE ROCK FENCE.  
ELECTION WAS MADE TO ESSENTIALLY HOLD THE DISTANCES, WHICH DID FIT WELL WITH THE CALLS TO THE ROCK  
FENCE. IT SHOULD BE NOTED THAT THE ROCK FENCES ARE IN REALITY WIDE MOUNDS OF STONE WITHOUT DISTINCT  
TOPS. THEREFORE, THE DISTANCE CALLS WERE HELD FIRM AS PER THE DEED, WHICH, IN GENERAL, FIT THE ROCK  
FENCE. THIS RESOLUTION MATCHED WELL WITH THE ADJOINING RAND ADDITION. THE BASIS OF BEARING FOR THIS  
SUBDIVISION WAS THE RAND ADDITION PLAT. IT SHOULD BE NOTED THAT SEVERAL OF THE MONUMENTS FOUND FROM  
THE PLAT OF RAND ADDITION WERE APPARENTLY SET AS 1-FOOT OFFSETS TO THE ACTUAL CORNERS, WHICH WAS  
NOT NOTED UPON THE PLAT. THIS OCCURS PARTICULARLY AT THE SOUTHEAST CORNER OF THE SUBJECT PROPERTY.  
WITH RESOLUTION OF THE BOUNDARY OF THE SUBJECT PROPERTY, THE INDIVIDUAL LOTS AND STREET WERE LAID OUT  
IN ACCORDANCE WITH THE APPROVED PRELIMINARY MAP OF THE SUBDIVISION.

SET AS SHOWN ON THE SURVEY, 5/8" X 30" REBAR WITH YELLOW PLASTIC CAP INSCRIBED "B BESEDA LS 50800".

### SURVEYOR'S CERTIFICATE:

I, BENJAMIN B. BESEDA, REGISTERED LAND SURVEYOR #50800 IN THE STATE OF OREGON, BEING FIRST DULY  
SWORN, DEPOSE AND SAY THAT I HAVE CORRECTLY SURVEYED AND MARKED WITH LEGAL MONUMENTS, ACCORDING TO  
ORS CHAPTER 92 AND CITY OF HOOD RIVER LAND USE DEVELOPMENT ORDINANCE, THE LAND REPRESENTED ON THE  
PLAT OF COLUMBIA CREST SUBDIVISION LOCATED IN GOVERNMENT LOT 6 OF SECTION 35, TOWNSHIP 3 NORTH,  
RANGE 10 EAST, WILLAMETTE MERIDIAN, CITY OF HOOD RIVER, HOOD RIVER COUNTY, OREGON, AND THAT THE 5/8" X  
30" REBAR WITH YELLOW PLASTIC CAP INSCRIBED "B BESEDA LS 50800", SET AT THE NORTHWEST CORNER OF THE  
SUBJECT PROPERTY, IS THE INITIAL POINT OF SAID SUBDIVISION, SAID INITIAL POINT BEARS NORTH 89°03'45" WEST  
394.00 FEET AND THENCE SOUTH 00°38'32" WEST 30.00 FEET FROM THE HOOD RIVER COUNTY BRASS CAP FOUND  
IN A MONUMENT BOX LOCATED AT THE INTERSECTION OF MAY STREET AND 27th. STREET, BEING AN INTERIOR  
CORNER OF THE WILLIAM JENKINS DLC #38, SAID INITIAL POINT IS FURTHER LOCATED ON THE SOUTH  
RIGHT-OF-WAY LINE OF MAY STREET. THE PLATTED PROPERTY IS DESCRIBED AS FOLLOWS.

BEGINNING AT THE AFORESAID INITIAL POINT; THENCE SOUTH 00°38'32" WEST 470.00 FEET; THENCE SOUTH 89°03'45"  
EAST 261.36 FEET; THENCE NORTH 00°38'32" EAST 470.00 FEET TO THE SOUTH RIGHT-OF-WAY LINE OF MAY  
STREET; THENCE ALONG SAID SOUTH RIGHT-OF-WAY LINE, NORTH 89°03'45" WEST 261.36 FEET TO THE INITIAL  
POINT.

CONTAINS 2.82 ACRES, MORE OR LESS.

SUBJECT TO ALL EASEMENTS, AGREEMENTS, AND RIGHTS-OF-WAY OF RECORD.

"PACIFICORP SHALL HAVE THE RIGHT TO INSTALL, MAINTAIN, AND  
OPERATE ITS ELECTRIC UTILITIES AND ALL OTHER RELATED FACILITIES  
WITHIN THE PUBLIC UTILITY EASEMENT IDENTIFIED ON THIS PLAT MAP  
AS MAY BE NECESSARY OR DESIRABLE IN SERVING THE LOTS  
IDENTIFIED HEREIN, INCLUDING THE RIGHT OF ACCESS TO SUCH  
FACILITIES AND THE RIGHT TO REQUIRE THE REMOVAL OF ANY  
OBSTRUCTIONS INCLUDING TREES AND VEGETATION THAT MAY BE  
PLACED WITHIN THE PUE AT THE LOT OWNER'S EXPENSE. AT NO TIME  
MAY ANY PERMANENT STRUCTURES BE PLACED WITHIN THE PUE OR  
ANY OTHER OBSTRUCTION WHICH INTERFERES WITH THE USE OF THE  
PUE WITHOUT THE PRIOR WRITTEN APPROVAL OF PACIFICORP."

### APPROVALS:

WE, THE UNDERSIGNED, SAY THAT WE HAVE EXAMINED  
THE PLAT OF "COLUMBIA CREST SUBDIVISION" IN THE CITY  
OF HOOD RIVER AND IN HOOD RIVER COUNTY, OREGON  
AND HERBY APPROVE SAID PLAT.

Mark A. Lase 2/10/04  
City Public Works & Engineering  
Director Date

Gynthia A. Walbridge 2/10/04  
City Planning Director Date

Paul T. Tates 2-10-04  
Hood River County Surveyor Date

Paul Schack 2/17/04  
County Board of Commissioners  
Chair Date

Paul A. Cummings 2/10/04  
Hood River City Mayor Date

Paul Tates 2/10/04  
Hood River City Recorder Date

### ENGINEER / SURVEYOR:

TENNESON ENGINEERING CORP.  
409 Lincoln Street,  
The Dalles, Oregon. 97058  
Ph. 541-296-9177  
FAX 541-296-6657



FILED

FEB 19 2004  
Certified to be a true and  
correct copy of the ORIGINAL  
Deed of Records & Assessment  
by Cindy Judah Deputy

MAR 3 2004  
Paul Tates  
COUNTY SURVEYOR  
DEPUTY

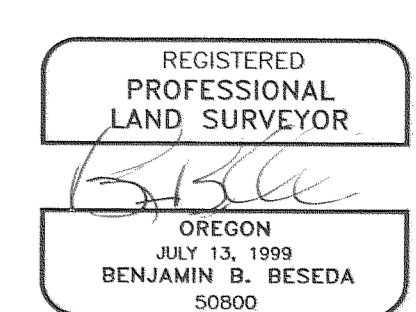

EXPIRES: 12/31/05