

NARRATIVE:

THE PURPOSE OF THIS SURVEY IS TO LOCATE THE LEASE AND EASEMENT POSITIONS AS DESCRIBED BY GROUND LEASE - MICROFILM No.930467 RECORDED FEBRUARY 17, 1993, DEPARTMENT OF RECORDS AND ASSESSMENTS, HOOD RIVER COUNTY.

COORDINATE VALUES WERE DERIVED BY GPS OBSERVATIONS FROM THE PONDER 2 H.A.R.N. STATION.

LOCATION OF SURVEY:

PORTION OF THE SOUTHEAST QUARTER OF SECTION 5, TOWNSHIP 2 NORTH, RANGE 11 EAST, WILLAMETTE MERIDIAN, HOOD RIVER COUNTY, OREGON.

LEGAL DESCRIPTION:

A parcel of land located in a portion of the East half of the Southeast quarter of Section 5, Township 2 North, Range 11 East, Willamette Meridian in the County of Hood River, and State of Oregon, being more particularly described as follows:

Commencing at an Axle monument, set in October, 1953 by Mart Perkins which is North 27°38'23" West, a distance of 1485.11 feet from the Southeast corner of said Section 5; thence North 13°17'41" West, a distance of 269.69 feet to a fence corner post at the point of beginning of the following described leasehold parcel.
 Thence South 89°50'59" West, a distance of 50.92 feet to a similar fence corner post; thence North 00°00'58" East, a distance of 50.22 feet to a similar fence corner post; thence North 89°24'30" East, a distance of 49.82 feet to a similar fence corner post; thence South 01°13'43" East, a distance of 50.61 feet to the point of beginning.

Together with a Guy Wire and Anchor Easement described as follows:
 Commencing at an Axle monument, set in October, 1953 by Mart Perkins which is North 27°38'23" West, a distance of 1485.11 feet from the Southeast corner of said Section 5; thence North 13°17'41" West, a distance of 269.69 feet to a fence corner post; Thence South 69°10'50" East, a distance of 92.86 feet to the point of beginning of the said Guy Wire and Anchor Easement.
 Thence North 30°44'44" West, a distance of 223.04 feet; thence South 29°15'53" West, a distance of 223.68 feet; thence North 89°07'01" East, a distance of 223.40 feet to the point of beginning.

Together with a 20 foot wide Utility Easement to the existing Pacific Power electrical line described as follows:
 Commencing at an Axle monument, set in October, 1953 by Mart Perkins which is North 27°38'23" West, a distance of 1485.11 feet from the Southeast corner of said Section 5; thence North 13°17'41" West, a distance of 269.69 feet to a fence corner post; Thence South 89°50'59" West, a distance of 50.92 feet to a similar fence corner post; thence North 00°00'58" East, a distance of 18.04 feet to the point of beginning of the centerline of said Utility Easement.
 Thence North 57°24'22" West, a distance of 130.96 feet to the termination point of said Utility Easement. The boundaries of said Utility Easement to be extended or shortened to meet at the West line of the previously described Leasehold parcel.

Together with a 20 foot wide Access Easement on the existing roadway to the previously described Leasehold parcel, said existing road being defined as starting at the "Old Dalles Road" and terminating at the previously described leasehold parcel.

BASIS OF BEARING:

NORTH AMERICAN DATUM 1983 (1998 ADJUSTMENT)
 STATE PLANE COORDINATE SYSTEM - OREGON NORTH.

REFERENCES:

HOOD RIVER COUNTY SURVEYORS OFFICE C.S.#92050.
 HOOD RIVER COUNTY ASSESSORS MAP 02N 11E 05, REVISED 02/24/03.
 GROUND LEASE - MICROFILM No.930467 RECORDED 2/17/1993, DEPARTMENT OF RECORDS AND ASSESSMENTS.

TOWER LOCATION:

LATITUDE: 45°40'58.002" NORTH
 LONGITUDE: 121°27'52.583" WEST (N.A.D.83)
 NORTHING: 736502 FEET
 EASTING: 7955575 FEET (STATE PLANE - OREGON NORTH)
 ELEVATION: 1994 FEET (N.A.V.D.88)

LEGEND:

- FOUND MONUMENT OF RECORD
- CALCULATED, NOT FOUND OR SET
- FENCE POST
- ⊖ POWER POLE
- x-x- FENCE
- ↓ GUY ANCHOR

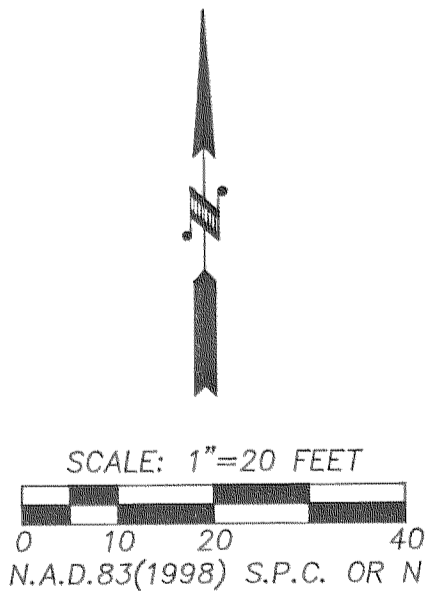

LEASE SITE SURVEY
 for
ALAMOSA SITE SURVEY #319 - WHITE SALMON

HOOD RIVER COUNTY 3" BRASS CAP FOUND AT THE SOUTHEAST CORNER OF SECTION 5.

REGISTERED PROFESSIONAL LAND SURVEYOR
 OREGON
 JULY 13, 1979
 ROY O. GAYLORD
 1815
 Expires: June, 2005

FILED
 DEC 5 2003
Ronald Roberts
 COUNTY CLERK
 HOOD RIVER, OREGON

TERRA SURVEYING
 DATE: NOVEMBER, 2003
 SCALE: 1" = 20'
 PROJECT: 203067
 ASSESSORS MAP: 2N 11E 05
 P.O. BOX 617
 HOOD RIVER, OREGON 97031
 PHONE & FAX: (541) 386-4531
 E-Mail: terra@gorge.net

1800-12-3-03 030 CS 2003 082