

LINE TABLE

| NO. | BEARING | DISTANCE |
|-----|---------------|----------|
| L1 | N 01°54'15" E | 26.03 |
| L2 | S 89°16'48" E | 13.00 |
| L3 | N 89°16'48" W | 13.00 |

| | EXISTING PARCEL SIZE | ADJUSTED PARCEL SIZE |
|-------------|----------------------|----------------------|
| TAX LOT 700 | 2.81 ACRES | 2.78 ACRES |
| TAX LOT 800 | 19,165 Sq. Ft. | 20,000 Sq. Ft. |

NARRATIVE:
 NO MAJOR DISCREPANCIES WERE FOUND.
 BLANKET EASEMENT FOR ELECTRICAL TRANSMISSION AND DISTRIBUTION TO PACIFIC POWER AND LIGHT COMPANY IN DEED BOOK 41 AT PAGE 136, HOOD RIVER COUNTY DEED RECORDS.
 RIGHTS OF THE PUBLIC IN ROADS AND HIGHWAYS.
 10' PUBLIC DEDICATION TO HOOD RIVER COUNTY.

LOCATION OF SURVEY:
 A PORTION OF GOVERNMENT LOT 6 IN SECTION 35, TOWNSHIP 3 NORTH, RANGE 10 EAST, W.M., HOOD RIVER COUNTY, OREGON.

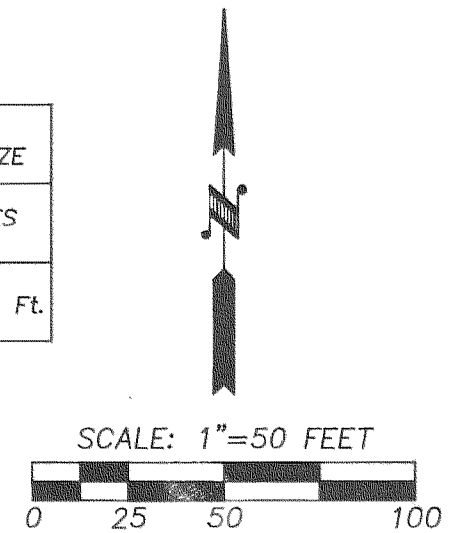

REGISTERED PROFESSIONAL LAND SURVEYOR
Roy O. Gaylord
 OREGON
 JULY 13, 1979
 ROY O. GAYLORD
 1815
 Expires: June, 2003

BASIS OF BEARING:
 1986 CITY OF HOOD RIVER DATUM.

REFERENCES:
 TERRA SURVEYING PROJECT NO. 8222, C.S. NO. 82064.
 TERRA SURVEYING PARTITION PLAT PROJECT NO. 9994PART.

- LEGEND:**
- SET 5/8" X 30" IRON ROD WITH PLASTIC CAP
 - FOUND TERRA 5/8" IRON ROD OF RECORD, EXCEPT WHERE NOTED
 - CALCULATED, NOT FOUND OR SET
 - () DEED OR PLAT CALL

FILED

TERRA SURVEYING

NOV 20 2001
Ronald Roberts
 COURT SURVEYOR
 DEPUTY

DATE: AUGUST, 2001
 SCALE: 1" = 50'
 PROJECT: 201007PROP

P.O. BOX 617
 HOOD RIVER, OREGON 97031
 PHONE & FAX: (541) 386-4531
 E-Mail terra@gorge.net
 TAX MAP 3N - 10 - 35BC

PROPERTY LINE ADJUSTMENT
 for
JAMES S. RUSSELL & CAROLYN SCHEMPF