

**NARRATIVE:**

THE PURPOSE OF THIS SURVEY WAS TO ADJUST LOTS 6,7,8,9,16,17,18 & 19, IN BLOCK 7, OF THE AMENDED PLAT OF IDLEWILDE ADDITION TO HOOD RIVER INTO 6 NEW LOTS. THE PROPERTY IS CURRENTLY COMPRISED OF TAX LOTS 2400, 2500, 2601 & 2602 OF HOOD RIVER COUNTY ASSESSORS MAP 3N-10-26DA. ADDITIONAL SURVEY INFORMATION FOR BLOCK 7 CAN BE FOUND ON TERRA SURVEYING PROJECT 2068PROP, DATED SEPTEMBER 2000. NO MAJOR DISCREPANCIES WERE FOUND DURING THE COURSE OF THIS SURVEY. SEE FACE OF SURVEY FOR FURTHER DETAILS.

NEW EASEMENTS WHICH ARE CREATED AS A RESULT OF THE PROPERTY LINE ADJUSTMENT ARE PARTIALLY SHOWN ON THIS MAP. HOWEVER, A COMPLETE LISTING OF EASEMENTS AFFECTING EACH ADJUSTED PARCEL WILL ONLY APPEAR WHEN OWNERSHIP IS TRANSFERRED.

**LOCATION OF SURVEY:**

PORTION OF BLOCK 7, OF THE AMENDED PLAT OF IDLEWILDE ADDITION TO HOOD RIVER, SECTION 26, TOWNSHIP 3 NORTH, RANGE 10 EAST, WILLAMETTE MERIDIAN, CITY OF HOOD RIVER, HOOD RIVER COUNTY, OREGON.

**REFERENCES:**

HOOD RIVER COUNTY DEED MICROFILM #890796.  
 HOOD RIVER COUNTY DEED MICROFILM #911512.  
 HOOD RIVER COUNTY DEED MICROFILM #982542.  
 HOOD RIVER COUNTY DEED MICROFILM #982547.  
 TERRA SURVEYING PROJECT 2068PROP, DATED SEPTEMBER 2000.

**BASIS OF BEARING:**

1986 CITY OF HOOD RIVER DATUM.

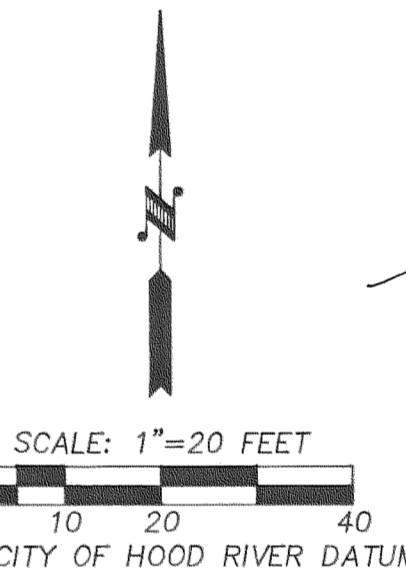

REGISTERED  
 PROFESSIONAL  
 LAND SURVEYOR

*Roy O. Gaylord*  
 OREGON  
 JULY 13, 1979  
 ROY O. GAYLORD  
 1815

Expires: June, 2001

**LEGEND:**

- SET 5/8" X 30" IRON ROD WITH PLASTIC CAP
- FOUND MONUMENT OF RECORD
- CALCULATED, NOT FOUND OR SET
- ( ) DEED OR PLAT CALL

**FILED**

MAR 12 2001

*Roy O. Gaylord*  
 COUNTY SURVEYOR  
 DEPUTY

TERRA SURVEYING

DATE: FEBRUARY, 2001  
 SCALE: 1" = 20'  
 PROJECT: 2079ADJ  
 ASSESSORS MAP: 3N-10-26DA  
 P.O. BOX 617  
 HOOD RIVER, OREGON 97031  
 PHONE & FAX: (541) 386-4531  
 terra@gorge.net

Prop 2-14-01 1400

2001 016

PROPERTY BOUNDARY LINE ADJUSTMENT  
 for  
 THE GREAT GADSBY HOLDING COMPANY, LLC.

