

FEB 16 11 35 AM '01

FOUND HOOD RIVER COUNTY BRASS CAP IN MONUMENT BOX @ THE NORTHWEST CORNER OF THE SOUTHEAST QUARTER OF THE NORTHEAST QUARTER OF SECTION 34.

MAY DRIVE  
N 88°54'08" W  
660.01  
(660.00)

FOUND HOOD RIVER COUNTY BRASS CAP IN MONUMENT BOX @ THE NORTHEAST CORNER OF THE NORTHWEST QUARTER OF THE SOUTHEAST QUARTER OF THE SOUTHEAST QUARTER OF SECTION 34.

LEGEND:

- SET 5/8" X 30" IRON ROD WITH PLASTIC CAP
- FOUND MONUMENT OF RECORD
- CALCULATED, NOT FOUND OR SET
- ✕ SET MARK ON ROCK
- ( ) DEED OR PLAT CALL
- ⊙ WELL HEAD LOCATION
- WELL

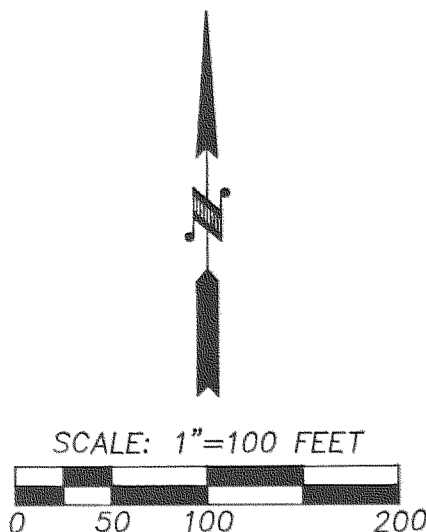

ARROW SET ON ROCK EDGE, POINT IS PROPERTY CORNER. LS 932 5/8" IRON ROD FOUND S77°25'W 1.34 FEET FROM MARK ON ROCK & NOT ACCEPTED AS CORNER.

NEW: 50.00 FOOT IN EVEN WIDTH, PUBLIC RIGHT -OF-WAY WITH UNDERGROUND UTILITIES OVER, UNDER AND ACROSS THE AREA SHOWN, PLUS A 57.0 FOOT RADIUS CUL-DE-SAC WITH A TEMPORARY TURN-A-ROUND.

LOT 4, LAND OF L.F. HENDERSON

NE CORNER OF LOT 5. FOUND 5/8" IRON ROD BY LS 932. HELD FOR LINE AND DISTANCE.

NEW: 10' ACCESS AND UTILITY EASEMENT CENTERED ON THE WELL HEAD OVER, UNDER AND ACROSS THE AREA SHOWN ON PARCEL 2; FROM 5' SOUTH OF THE WELL HEAD TO THE CUL-DE-SAC RIGHT OF WAY & 5' EAST OF THE WELL HEAD TO THE EAST BOUNDARY LINE OF PARCEL 3.

NOTE: THE WELL CASING IS 0.46 FEET OUTSIDE OF THE CUL-DE-SAC EASEMENT RIGHT OF WAY.

THE SUM OF THE DISTANCES ALONG THE WEST LINES OF THE LAND OF L.F. HENDERSON PLAT IS 20.03 CHAINS AND NOT 20.04 AS SHOWN ON THE PLAT. I HELD THE SUM OF THE ORIGINAL DISTANCES I.E. 20.03 CHAINS (1321.98') TO CALCULATE THE POSITION FOR THE SOUTHWEST CORNER OF THE ORIGINAL PLAT. I HELD THE DISTANCES ALONG THIS LINE AS SHOWN AS NOT TO DISRUPT PRIOR SURVEYS WHICH USED THE PLAT CALL DISTANCES.

PARCEL 3  
1.24 ACRES, ±  
SOUTH 50' FOR PARCEL 2 SEPTIC DRAIN FIELD 164.00

PARCEL 2  
1.76 ACRES, ±

PARCEL 1  
1.76 ACRES, ±

FILE

FEB 27 2001

*Royal J. Galt*  
COUNTY CLERK

CALCULATED SOUTHWEST CORNER OF THE SOUTHEAST QUARTER OF THE NORTHEAST QUARTER OF SECTION 34 (ASSUMED TO BE THE CENTER OF SECTION CORNER). THIS CORNER IS THE CALCULATED SOUTHWEST CORNER OF THE ORIGINAL LAND OF L.F. HENDERSON.

PARTITION PLAT  
for

KERRI KENT, SCOTT & SUSAN SORENSEN

NARRATIVE:

FOUND NO MAJOR DISCREPANCIES. HELD FOUND MONUMENTS AS NOTED. SEE NOTE CONCERNING THE WEST LINE OF THE ORIGINAL PLAT.

NOTE:

NO EASEMENTS OF RECORD APPEAR ON THE ABOVE REFERENCED WARRANTY DEED.

PARCELS 2 AND 3 WILL BE REQUIRED TO HAVE SAND FILTRATION SEPTIC SYSTEMS UNTIL SUCH TIME AS THE PARCELS MAY CONNECT TO CITY SEWER.

WETLANDS ARE LOCATED ON ALL THREE PARCELS CREATED BY THIS PARTITION. A WETLAND DELINEATION IS AVAILABLE FOR REVIEW IN COUNTY PLANNING FILE #00-131. ANY CONSTRUCTION IN THE WETLANDS AND WATERWAYS MAPPED ON THE DELINEATION REPORT IS SUBJECT TO REVIEW, AND POTENTIAL REGULATION, BY THE DIVISION OF STATE LANDS AND THE U.S. ARMY CORPS OF ENGINEERS.

ANY STRUCTURES RELATED TO THE WELL SHALL BE LOCATED OUTSIDE OF THE CUL-DE-SAC RIGHT OF WAY.

LOCATION OF SURVEY:

LOTS 5 & 6, THE LAND OF L.F. HENDERSON LOCATED IN THE SOUTHEAST QUARTER OF THE NORTHEAST QUARTER OF SECTION 34, TOWNSHIP 3 NORTH, RANGE 10 EAST, W.M., HOOD RIVER COUNTY, OREGON.

BASIS OF BEARING:

1986 CITY OF HOOD RIVER DATUM.

EASEMENTS:

ACCESS AND UTILITY EASEMENT AS SHOWN AND NOTED. THERE IS TO BE A 50 FOOT "NO BUILD" EASEMENT THAT EXTENDS THE ACCESS EASEMENT TO THE WEST ACROSS LOT 3.

REFERENCES:

PLAT MAP OF THE LAND OF L.F. HENDERSON, DATED JULY 1905. HOOD RIVER COUNTY SURVEY NO. 87022, PLS 1815, DATED MAY 1987. HOOD RIVER COUNTY SURVEY NO. 97057, PLS 1028, DATED SEPT. 1997. HOOD RIVER COUNTY SURVEY NO. 96032, PLS 932, DATED MAY 1996. HOOD RIVER COUNTY SURVEY NO. 93106, PLS 1028, DATED DEC. 1993.

FILINGS:

DEDICATION OF PUBLIC RIGHT-OF-WAY OF PARTITION PLAT 20010547 FILED IN HOOD RIVER COUNTY MICROFILM RECORDS NO. 20010547, DATED

Feb. 16<sup>th</sup>, 2001, DEED RECORDS, COUNTY OF HOOD RIVER AND STATE OF OREGON.

EASEMENT AND AGREEMENT BETWEEN ADJOINING PROPERTY OWNERS FOR USE, MAINTENANCE AND REPAIR OF WATER SYSTEM OF PARTITION PLAT 20010547 FILED IN HOOD RIVER COUNTY MICROFILM RECORDS NO. 20010548, DATED

February 14, 2001, DEED RECORDS, COUNTY OF HOOD RIVER AND STATE OF OREGON.

GRANT OF EASEMENT, LOCATING PARCEL 2'S SEPTIC DRAIN FIELD ON THE SOUTHERN 50' OF PARCEL 3 OF PARTITION PLAT 20010547 FILED IN HOOD RIVER COUNTY MICROFILM RECORDS NO. 20010551, DATED

February 14, 2001, DEED RECORDS, COUNTY OF HOOD RIVER AND STATE OF OREGON.

DECLARATION OF DEED RESTRICTION FOR THE OWNERS TO ACKNOWLEDGE THAT THE PARCELS WILL CONNECT TO ICE FOUNTAIN AT SUCH TIME AS ICE FOUNTAIN WATER DISTRICT SERVICES BECOME AVAILABLE OF PARTITION PLAT 20010547 FILED IN HOOD RIVER COUNTY MICROFILM RECORDS NO. 20010552, DATED

February 14, 2001, DEED RECORDS, COUNTY OF HOOD RIVER AND STATE OF OREGON.

DECLARATION OF DEED RESTRICTIONS, CONCERNING PARCEL 3'S NORTHERN FIFTY FOOT NO-BUILD EASEMENT OF PARTITION PLAT 20010547 FILED IN HOOD RIVER COUNTY MICROFILM RECORDS NO. 20010550, DATED

February 14, 2001, DEED RECORDS, COUNTY OF HOOD RIVER AND STATE OF OREGON.

AGREEMENT BETWEEN ADJOINING PROPERTY OWNERS FOR ROADWAY MAINTENANCE, REPAIR AND UTILITIES OF PARTITION PLAT 20010547 FILED IN HOOD RIVER COUNTY MICROFILM RECORDS NO. 20010549, DATED

February 14, 2001, DEED RECORDS, COUNTY OF HOOD RIVER AND STATE OF OREGON.

STATE OF Oregon }  
COUNTY OF Hood River } s.s.  
Subscribed and sworn to before me on this 14 day of February, 2001  
by *Emily Knowles*

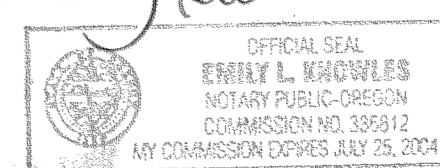

(Seal)

STATE OF Oregon }  
COUNTY OF Hood River } s.s.  
Subscribed and sworn to before me on this 14 day of February, 2001  
by *Emily Knowles*



(Seal)

FEB 23 2001

Certified to be a true and correct copy of the ORIGINAL.  
Dept. of Records & Assessment  
by *Deek Shurt* Deputy

TERRA SURVEYING

DATE: FEBRUARY, 2001  
SCALE: 1" = 100'  
PROJECT: 9881PLAT

P.O. BOX 617  
HOOD RIVER, OREGON 97031

PHONE & FAX: (541) 386-4531  
E-Mail terra@gorge.net

APPROVALS

I hereby certify that all taxes and assessments due hereon have been fully paid as required by law.

*Doreen Boroway*  
Hood River County Director of Budget and Finance

I hereby certify this partition was examined and approved as of this 12<sup>TH</sup> day of FEBRUARY, 2001.

*Royal J. Galt*  
Hood River County Surveyor

I hereby certify this partition was examined and approved as of this 15<sup>TH</sup> day of FEBRUARY, 2001.

Planning File Number #00-131  
*M. Donahue*  
Hood River County Planning Director