

FOUND AND ACCEPTED WAGON SKEIN MONUMENTING THE NORTHEAST CORNER OF THE NORTHWEST QUARTER OF THE SOUTHEAST QUARTER. SEE TERRA PROJECT 9336 FOR DETAILS.

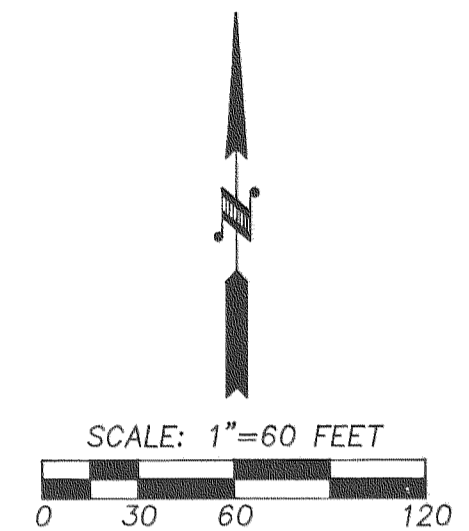

REGISTERED PROFESSIONAL LAND SURVEYOR

Roy O. Gaylord
 OREGON
 JULY 13, 1979
 ROY O. GAYLORD
 1815

Expires June, 2001

BASIS OF BEARING:
 1986 CITY OF HOOD RIVER DATUM.

REFERENCES:
 TERRA SURVEYING PROJECT No. 9336, DECEMBER, 1993.
 COUNTY SURVEYOR'S FILE No. 0313, MARCH 1964.
 COUNTY SURVEYOR'S FILE No. 0332, MAY 6, 1950.
 COUNTY SURVEYOR'S FILE No. 0308, DECEMBER, 1960.

LOCATION OF SURVEY:
 A PORTION OF THE NORTHWEST QUARTER OF THE SOUTHEAST QUARTER OF SECTION 2, TOWNSHIP 2 NORTH, RANGE 10 EAST, W.M., HOOD RIVER COUNTY, OR.

- LEGEND:
- ⊙ SET 1" HEAD BY 3" LONG "SURVEY MARKER"
 - SET 5/8" X 30" IRON ROD WITH PLASTIC CAP
 - FOUND MONUMENT OF RECORD
 - ■ CALCULATED, NOT FOUND OR SET
 - () DEED OR PLAT CALL

NARRATIVE:

TERRA SURVEYING ONLY SURVEYED THE DEED LINES OF TAX LOT 3600 AND THAT PORTION OF TAX LOT 3900 BEING ADJUSTED. NO ATTEMPT WAS MADE TO SURVEY ALL THE DEED LINES OF TAX LOT 3900.

THE COUNTY SURVEYOR'S FILE No. 0313 BY GEORGE FRY AS THE "PLAT OF BRADLEY PROPERTY", DATED MARCH, 1964, APPEARS TO HAVE BEEN COMPLETED PRIOR TO THE WARRANTY DEED IN DEED BOOK 76 AT PAGE 194 FROM WILLIAM R. BRADLEY TO ELDON BRADLEY. I, THEREFORE, ASSUMED THE FOUND DEED PIPE WOULD CONTROL THE LOCATION OF THE SURVEYED PARCEL.

TERRA SURVEYING

DATE: JANUARY, 2000
 SCALE: 1" = 60'
 PROJECT: 99104ADJ
 P.O. BOX 617
 HOOD RIVER, OREGON 97031
 PHONE & FAX: (541) 386-4531
 E-MAIL: terra@gorge.net

FILED
 JAN 28, 2000
Rich G. Up
 COUNTY SURVEYOR

BOUNDARY LINE ADJUSTMENT
 for
 JOHN J.F. SHERRERD, MARY PENN HUNTING & ET AL.

