

FEB 8 1999

Certified to be a true and correct copy of the ORIGINAL Dept. of Records & Assessment by *D. Forcum* Deputy

FILED RECORDS AND ASSESSMENT HOOD RIVER CO.

FEB 8 1 09 PM '99

NARRATIVE:  
NO MAJOR DISCREPANCIES WERE FOUND.

File Number 9902  
Instrument received on the 8th day of February, 1999 at 1:09 P.M.

Hood River County Director of Records and assessments.

LOCATION OF SURVEY:

PARCEL 2 OF THE BRIAN WATTS PARTITION, HOOD RIVER COUNTY PARTITION PLAT FILE NUMBER 9816, RECORDED JUNE 16, 1998, LOCATED IN THE SOUTHWEST QUARTER OF SECTION 36, TOWNSHIP 3 NORTH, RANGE 10 EAST, W.M., HOOD RIVER COUNTY, OR.

SURVEYOR'S CERTIFICATE

I, Roy O. Gaylord, being first duly sworn, depose and say that I have correctly surveyed and marked with proper monuments the lands represented on this Partition Plat, the boundaries being described in Instrument # 912604, dated November 7, 1991, and # 982281, dated May 26, 1998, Hood River County Deed Records to Brian Culbert Watts.

REGISTERED PROFESSIONAL LAND SURVEYOR

*Roy O. Gaylord*  
OREGON  
JULY 13, 1979  
ROY O. GAYLORD  
1815

Expires: June, 1999

BASIS OF BEARING:

PRIOR TO 1986 CITY OF HOOD RIVER DATUM.

REFERENCES:

PARCEL 2 OF THE BRIAN WATTS PARTITION, HOOD RIVER COUNTY PARTITION PLAT FILE NUMBER 9816, RECORDED JUNE 16, 1998.

HOOD RIVER COUNTY SURVEYOR'S FILE #83060.  
HOOD RIVER COUNTY CLERK'S FILE # 802118.  
HOOD RIVER COUNTY SURVEYOR'S FILE #89097.  
TERRA PROJECT #8336 DATED JULY, 1983.  
TERRA PROJECT #9815 DATED JUNE, 1998.

LEGEND:

- SET 5/8" X 30" IRON ROD WITH PLASTIC CAP
- FOUND MONUMENT OF RECORD
- CALCULATED, NOT FOUND OR SET
- ( ) DEED OR PLAT CALL
- CL/CL CENTER LINE/CENTER LINE

ACKNOWLEDGEMENTS

We the owner(s) of the land shown herein, hereby declare that this division of land has been made with our free consent and in accordance with our desires.

*B. Culbert* 2-3-99  
OWNER DATE

*Jamie Watts* 2-3-99  
OWNER DATE

OWNER STATE OF Oregon DATE  
COUNTY OF Hood River Co., OR s.s.  
Subscribed and sworn to before me on this 3 day of February, 1999  
by *Jamie Watts*

OFFICIAL SEAL  
JANIS S. GAYLORD  
NOTARY PUBLIC-OREGON  
COMMISSION NO. 305309  
MY COMMISSION EXPIRES DEC. 12, 2001

(Seal)

APPROVALS

I hereby certify that all taxes and assessments due hereon have been fully paid as required by law.

*Janet Ann Chamness CPA*  
Hood River County Director of Budget and Finance

I hereby certify this partition was examined and approved as of this 1 day of February, 1999.

*Richard G. Stahl*  
Hood River County Surveyor

I hereby certify this partition was examined and approved as of this 8 day of February, 1999.

Planning File Number #98-530  
*Katherine A. Skelton*  
Hood River County Planning Director

MONUMENT OF RECORD:  
5/8" IRON ROD FOUND IN MONUMENT CASE AT CL/CL INTERSECTION OF 8th STREET AND KROPP COURT.

MONUMENT OF RECORD:  
5/8" IRON ROD FOUND, BENT IN THE GROUND.

PARCEL 1 OF BRIAN WATTS PARTITION, HOOD RIVER COUNTY PARTITION PLAT FILE NUMBER 9816, RECORDED JUNE 16, 1998.

PARCEL 1  
5,055 Sq. Ft. ±

PARCEL 2  
7,305 Sq. Ft. ±

10 FOOT DEDICATED TO THE PUBLIC ON BRIAN WATTS PARTITION, HOOD RIVER COUNTY PARTITION PLAT FILE NUMBER 9816, RECORDED JUNE 16, 1998.

FOUND 5/8" IRON ROD IN MONUMENT CASE AT CL/CL INTERSECTION OF ELIOT AVENUE AND 8th STREET

FOUND PK NAIL AT ELIOT AVENUE AND TUCKER RD.  
1983 DATUM IN METERS.  
N 225,676.94  
E 2,420,276.25

CALCULATED POSITION OF 1/16 CORNER. REPOSITIONED IN ACCORD WITH A 1989 RESEARCH NARRATIVE OF SECTION 1, TOWNSHIP 2 NORTH, RANGE 10 EAST, W.M. THE CALCULATED CORNER BEARS S 77° 13' 29" WEST AT 2.04' FROM THE FOUND PIPE. I ACCEPTED THE PIPE AS THE 1/16 CORNER BECAUSE IT WAS REASONABLY CLOSE TO THE CALCULATED 1/16 CORNER AND BY ACCEPTING THE PIPE PRIOR SURVEYS WOULD BE LEFT UNDISTURBED.

MONUMENT OF RECORD:  
1" IRON PIPE FOUND IN CENTER OF ELIOT AVENUE EXISTING 1/16 CORNER.

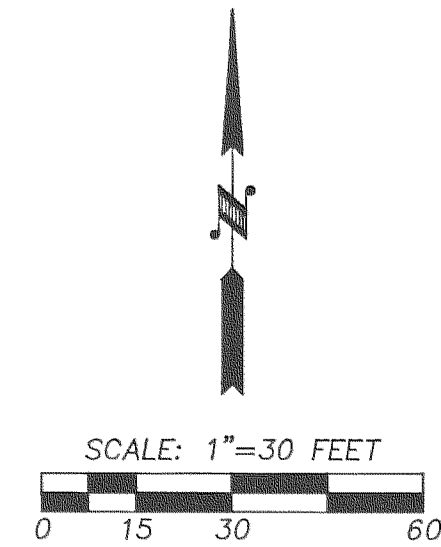

NO.	BEARING	DISTANCE
L1	S 89°33'44" E	10.97
L2	S 77°17'11" W	2.06
L3	S 89°27'37" E	20.00
L4	S 00°39'10" W	20.00
L5	S 00°39'10" W	10.00
L6	S 89°27'37" E	0.96 (1.00')
L7	S 89°27'37" W	0.96 (1.00')
L8	N 00°39'10" E	10.00
L9	N 00°39'10" E	20.00

PARTITION PLAT  
for  
BRIAN WATTS

FILED

APR 21, 1999  
*Richard G. Stahl*  
COUNTY SURVEYOR

TERRA SURVEYING

DATE: JANUARY, 1999  
SCALE: 1" = 30'  
PROJECT: 9907PLAT

P.O. BOX 617  
HOOD RIVER, OREGON 97031

PHONE & FAX: (541) 386-4531  
E-Mail terra@gorge.net

#- 99027