

(THIS EASEMENT SQUARE FOOTAGE IS NOT COUNTED IN THE ADJUSTED PARCEL 2'S AREA OF 7,145 SQUARE FEET.)
 EASEMENT TO THE CITY OF HOOD RIVER DEED BOOK 24 @ PAGE 233.

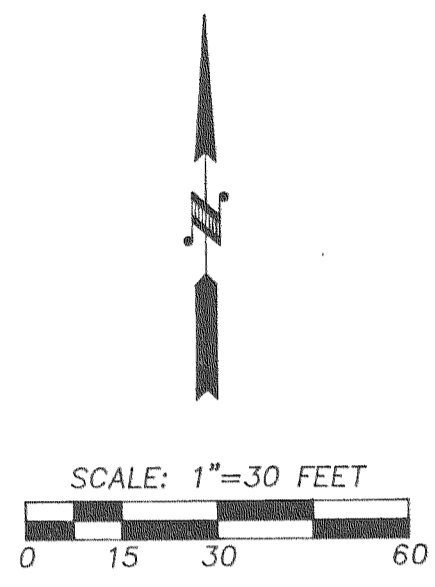

REGISTERED PROFESSIONAL LAND SURVEYOR
Roy O. Gaylord
 OREGON
 JULY 13, 1979
 ROY O. GAYLORD
 1815
 Expires June, 1999

BASIS OF BEARING:
 1986 CITY OF HOOD RIVER DATUM

LINE TABLE

NO.	BEARING	DISTANCE
L1	S 28°12'21\" E	18.87
L2	S 28°34'09\" E	18.84
L3	N 88°54'16\" W	0.65
L4	S 01°06'58\" W	2.00
L5	N 01°06'58\" E	2.00

- LEGEND:
- SET 5/8\" X 30\" IRON ROD WITH PLASTIC CAP
 - ⊙ P-K NAIL IN CONCRETE SLAB
 - ⊙ 1/4 INCH DRILL HOLE IN STEEL PLATE
 - ⊙ RAILROAD SPIKE IN ASPHALT WITH 'X'
 - ⊕ FOUND BRASS SCREWS OF RECORD.
 - FOUND MONUMENT OF RECORD
 - CALCULATED, NOT FOUND OR SET
 - () DEED OR PLAT CALL

NARRATIVE:
 FOUND NO MAJOR DISCREPANCIES.

REFERENCES:
 LS 385 WORK ORDER No. 5397, DATED 9-01-1977
 COUNTY SURVEYORS No. (C.S.) 89051.
 TERRA SURVEYING PROJECT 9701 IN
 C.S. No. 97018.

LOCATION OF SURVEY:
 A PORTION OF LOTS 1, 2, AND 8 OF BLOCK 4, OF THE ORIGINAL TOWN OF HOOD RIVER, OREGON.
 3N - 10E - 25DC, TAX LOTS 2700 AND 3200.

FILED
 APR 21, 1999
Rial G. Arnold
 COUNTY SURVEYOR

BOUNDARY LINE ADJUSTMENT SURVEY
 for
 W.T. & CAROL NELSON

TERRA SURVEYING
 DATE: FEBRUARY, 1999
 SCALE: 1\" = 30'
 PROJECT: 9912
 P.O. BOX 617
 HOOD RIVER, OREGON 97031
 PHONE & FAX: (541) 386-4531