

EAST QUARTER CORNER  
SECTION 33  
POSITION PER CS# 7653

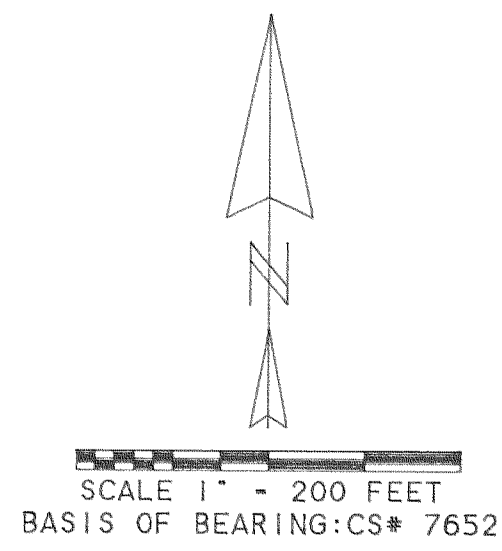

LINE	BEARING	DISTANCE
L 1	N 09° 44' 54" E	31.86'
L 2	N 10° 05' 20" W	66.08'
L 3	S 88° 52' 47" W	129.69'
L 4	N 88° 52' 47" E	80.32'
L 5	N 13° 11' 09" E	25.96'

**REGISTERED PROFESSIONAL LAND SURVEYOR**  
*Kevin Dowd*  
OREGON  
JULY 26, 1989  
KEVIN DOWD  
2393  
RENEW DATE: 12-31-99  
JULY 22, 1998

**LEGEND:**

- SET 1/2" IRON ROD WITH YELLOW PLASTIC CAP STAMPED "WYEAST SURVEYS PLS 2393"

**NARRATIVE:**

THE PURPOSE OF THIS SURVEY IS TO MONUMENT THE LINES AND FILE FOR RECORD A PARTITION OF TRACT 1 OF THOSE PARCELS OF LAND DESCRIBED IN DEED RECORDED IN BOOK 73, PAGE 683, HOOD RIVER COUNTY DEED RECORDS. PARCEL 1 IS OVER 10 ACRES AND WAS NOT SURVEYED. THE CENTERLINE OF THE HOOD RIVER WAS ESTABLISHED FROM A COMBINATION OF FIELD DATA AND SCALED AERIAL PHOTOS.

**EASEMENTS: (NOT SHOWN ON ANNEXED MAP)**

20 FOOT WIDE IRRIGATION PIPELINE EASEMENT GRANTED TO THE MIDDLE FORK IRRIGATION DISTRICT BY FEE NO. 670375. LOCATION IS NON SPECIFIC.

**FILED**  
OCT 5, 1998  
*Rial G. Sell*  
COUNTY SURVEYOR  
CLERK

**PARTITION PLAT**

SITUATED IN THE SOUTHEAST QUARTER OF SECTION 33  
T1 NORTH, R10 EAST, W.M.  
HOOD RIVER COUNTY OREGON

FOR: SCOTT HALLIDAY

8/5/98  
Certified to be a true and correct copy of the ORIGINAL  
Dept. of Records & Assessment  
by *J. Sell* Deputy

WYEAST SURVEYS  
KEVIN DOWD  
4399 WOODWORTH DR  
MT. HOOD, OR 97041  
(541) 352-6065

FILED  
RECORDS AND ASSESSMENT  
HOOD RIVER CO.  
AUG 6 10 42 AM '98

Partition Plat # 9821  
Instrument received on the 6<sup>th</sup> day of AUGUST 1998 at 10:42 AM  
Hood River Director of Records and Assessments

**SURVEYOR'S CERTIFICATE:**  
I, *Kevin Dowd* being first duly sworn, depose and say that I have correctly surveyed and marked with proper monuments the lands represented on this Partition Plat, the boundaries being described in instrument: BOOK 73, PAGE 683  
Hood River County Deed Records to HALLIDAY ORCHARDS, INC.

**ACKNOWLEDGEMENTS:**  
We the owner(s) of the land shown herein, hereby declare that this division of land has been made with our free consent and in accordance with our desires.

OWNER: *Scott Halliday* DATE: Aug 6 1998  
STATE OF OREGON  
COUNTY OF Hood River  
Subscribed and sworn to before me this 6<sup>th</sup> day of August 1998  
by *Kevin Dowd*  
**OFFICIAL SEAL**  
NICOLE M. COWART  
NOTARY PUBLIC - OREGON  
COMMISSION NO. 043372  
MY COMMISSION EXPIRES APR. 23, 1998  
Notary Public for the State of Oregon  
My commission expires 4-23-99

OWNER: \_\_\_\_\_ DATE: \_\_\_\_\_  
STATE OF \_\_\_\_\_  
COUNTY OF \_\_\_\_\_  
Subscribed and sworn to before me this \_\_\_\_\_ day of \_\_\_\_\_ 19\_\_\_\_  
by \_\_\_\_\_

Notary Public for the State of \_\_\_\_\_  
My commission expires \_\_\_\_\_

**APPROVALS:**  
I hereby certify that all taxes and assessment due hereon have been fully paid as required by law.

Hood River County Director of Budget and Finance  
*Scott Halliday*  
I hereby certify this partition was examined and approved as of this 6<sup>th</sup> day of August 1998  
by *Rial G. Sell*  
Hood River County Surveyor

I hereby certify this partition was examined and approved as of this 6<sup>th</sup> day of August 1998  
Planning File Number #98-274  
Hood River Planning Director  
*Scott Halliday*