

Filed for Record:
Dec. 2, 1997
@ 11:16 A.M.
#973940

FILED
RECORDS AND ASSESSMENT
HOOD RIVER CO.
DEC 2 11 16 AM '97

LINE TABLE

NO.	BEARING	DISTANCE
L1	N 00°59'08" E	26.07
L2	S 00°59'08" W	29.69
L3	S 72°01'30" W	37.82
L4	S 45°10'57" W	36.16
L5	S 43°02'25" W	29.94
L6	S 53°38'39" W	38.44
L7	N 73°51'31" W	38.10
L8	S 89°00'52" E	39.16
L10	S 10°36'15" W	11.47
L11	S 28°52'50" W	32.64
L12	S 64°37'53" W	34.93
L13	N 01°33'33" E	14.57

CURVE TABLE

NO.	DELTA	RADIUS	LENGTH	CHORD BEARING	CHORD DISTANCE
C1	90°00'00"	15.00	23.56	S 46°30'28" W	21.21
C2	90°00'00"	15.00	23.56	S 43°29'32" E	21.21

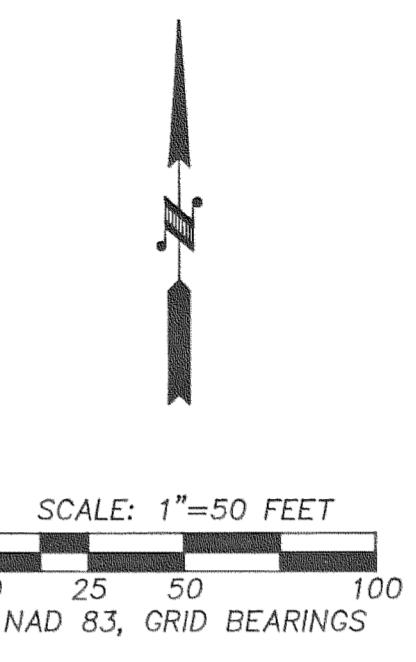

NARRATIVE:

THE CENTERLINE OF ARROWHEAD AVENUE IS LOCATED 209' NORTH OF A 1/2" IRON ROD LOCATED BY THE HOOD RIVER COUNTY SURVEYOR AT THE INTERSECTIONS OF THE CENTERLINES OF INDIAN CREEK ROAD AND BROOKSIDE AVENUE AS MEASURED ALONG THE CENTERLINE OF INDIAN CREEK ROAD.

ALL LOT AFFECTED BY INDIAN CREEK SHALL MAINTAIN A MINIMUM IF A 50 FOOT SETBACK FROM THE THREAD OF INDIAN CREEK AND ABOVE THE 100 YEAR FLOOD PLAIN AS INDICATED BY THE 3 ELEVATIONS PLACED ON THE FACE OF THIS PLAT.

REGISTERED PROFESSIONAL LAND SURVEYOR
Roy O. Gaylord
OREGON
JULY 13, 1979
ROY O. GAYLORD
1815
Expires: June, 1999

BASIS OF BEARING:
NAD 1983, OREGON NORTH, GRID BEARINGS

VERTICAL DATUM:
1986 CITY OF HOOD RIVER DATUM

REFERENCES:
TERRA SURVEY FOR GLENN MARSH, 1986.
PROPERTY BOUNDARY SURVEY FOR BROOKSIDE, INC. SUNNYSIDE PLAT.
1986 CITY OF HOOD RIVER TOPOGRAPHIC MAPS. A FLOOD PLAIN ANALYSIS FOR THE PROPOSED INDIAN CREEK GOLF COURSE. REGISTERED PROFESSIONAL ENGINEER No. 10954, DATED FEBRUARY, 1990.

LOCATION OF SURVEY:
LOT 7 OF SUNNYSIDE IN THE NORTHWEST QUARTER OF SECTION 2, TOWNSHIP 2 NORTH, RANGE 10 EAST, W.M., HOOD RIVER COUNTY, OREGON. TAX LOT 1600, 2N 10E SECTION 2B.

- LEGEND:**
- SET 5/8" X 30" IRON ROD WITH RED PLASTIC CAP
 - FOUND MONUMENT OF RECORD
 - CALCULATED, NOT FOUND OR SET
 - () DEED OR PLAT CALL

FOUND 1/2" IRON ROD AT C/L INDIAN CREEK ROAD AND C/L BROOKSIDE AVENUE (SEE NARRATIVE)

TERRA SURVEYING

DATE: NOVEMBER, 1997
SCALE: 1" = 50'
PROJECT: 9644-1

P.O. BOX 617
HOOD RIVER, OREGON 97031
PHONE & FAX: (541) 386-4531
terra@gorge.net

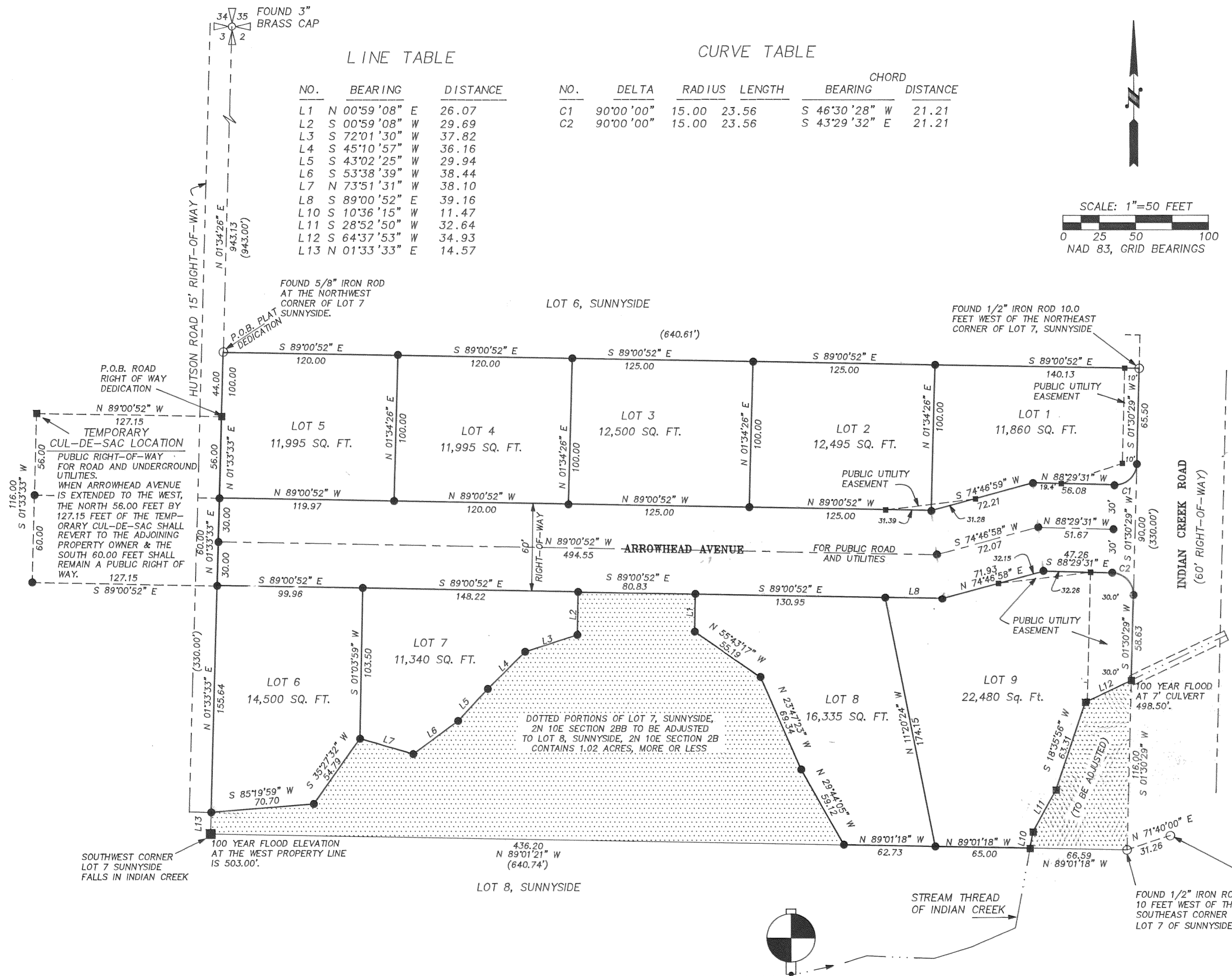

OWNERS:

M & M REALTY, A PARTNERSHIP
CARL H. MARTIN & DAVID A. MARTIN
3419 BROKEN TEE AVENUE
(541) 386-2792

BROOKSIDE, INC.
ROBERT L. HANEL, PRESIDENT, BROOKSIDE, INC.
3605 BROOKSIDE AVENUE
(541) 386-7770

VERTICAL DATUM
BRIDGE No. 3
GPS TACK @ CENTER LINE = 500.65
100 YEAR FLOOD ELEVATION = 500.20'

PLAT OF
INDIAN SPRINGS

FILED
DEC 30, 1997
Richard G. Smith
COUNTY SURVEYOR

DEC 2 1997
Certified to be a true and correct copy of the ORIGINAL. Dept. of Records & Assessment by *[Signature]* Deputy

APPROVALS:

THE PLAT OF INDIAN SPRINGS WAS EXAMINED AND APPROVED BY ME
THIS 25 DAY OF NOVEMBER, 1997
John F. Wilson
HOOD RIVER COUNTY DIRECTOR OF PUBLIC WORKS

THE PLAT OF INDIAN SPRINGS WAS EXAMINED AND APPROVED BY ME
THIS 20 DAY OF NOVEMBER, 1997
David A. Martin
CHAIRPERSON, HOOD RIVER COUNTY PLANNING COMMISSION

THE PLAT OF INDIAN SPRINGS WAS EXAMINED AND APPROVED BY ME
THIS 2nd DAY OF December, 1997
Stephen S. Hunt
HOOD RIVER COUNTY PLANNING DEPARTMENT

THE PLAT OF INDIAN SPRINGS WAS EXAMINED AND APPROVED BY ME
THIS 18 DAY OF Nov., 1997
Richard G. Smith
HOOD RIVER COUNTY SURVEYOR

THE PLAT OF INDIAN SPRINGS WAS EXAMINED AND APPROVED BY ME
THIS 20th DAY OF November, 1997
Angela Mollenbeck
FARMER'S IRRIGATION DISTRICT

THE PLAT OF INDIAN SPRINGS WAS EXAMINED AND APPROVED BY ME
THIS 25th DAY OF November, 1997
Ron Thomas-Wiley
CITY OF HOOD RIVER PLANNER

THE PLAT OF INDIAN SPRINGS WAS EXAMINED AND APPROVED BY ME
THIS 1 DAY OF December, 1997
Dawson G. Kowalski
CHAIRPERSON, HOOD RIVER COUNTY COMMISSION

THE PLAT OF INDIAN SPRINGS WAS EXAMINED AND APPROVED BY ME
THIS 1 DAY OF December, 1997
Chad A. Brown
HOOD RIVER COUNTY COMMISSIONER

THE PLAT OF INDIAN SPRINGS WAS EXAMINED AND APPROVED BY ME
THIS 1 DAY OF December, 1997
Paul S. Goff
HOOD RIVER COUNTY COMMISSIONER

THE PLAT OF INDIAN SPRINGS WAS EXAMINED AND APPROVED BY ME
THIS 1 DAY OF December, 1997
Robert E. Best
HOOD RIVER COUNTY COMMISSIONER

THE PLAT OF INDIAN SPRINGS WAS EXAMINED AND APPROVED BY ME
THIS 1 DAY OF December, 1997
Carol S. Goff
HOOD RIVER COUNTY COMMISSIONER

THE DIRECTOR OF RECORDS AND ASSESSMENTS, AND THE DIRECTOR OF BUDGET AND FINANCE AND TAX COLLECTOR, RESPECTIVELY, OF HOOD RIVER COUNTY, OREGON, HEREBY CERTIFY THAT WE HAVE EXAMINED THE PLAT OF "INDIAN SPRINGS" IN THE COUNTY OF HOOD RIVER AND THAT THE NAME ADOPTED FOR SAID PLAT IS A PROPER NAME AND NOT INCLUDED IN ANY OTHER SUBDIVISION IN HOOD RIVER COUNTY, AND FURTHER CERTIFY THAT ALL ASSESSMENTS DUE HEREON HAVE BEEN FULLY PAID AS REQUIRED BY LAW AND WE HEREBY APPROVE SAID PLAT.

Daniel Guy Chammoss
HOOD RIVER COUNTY DIRECTOR OF BUDGET
FINANCE & TAX COLLECTOR

Sandra L. Berry
HOOD RIVER COUNTY DIRECTOR OF RECORDS,
AND ASSESSMENTS

SURVEYOR'S CERTIFICATE:

I, ROY O. GAYLORD, REGISTERED LAND SURVEYOR FOR THE STATE OF OREGON, BEING FIRST DULY SWORN, DEPOSE AND SAY THAT I HAVE CORRECTLY SURVEYED AND MARKED WITH LEGAL MONUMENTS THE LAND REPRESENTED ON THE PLAT OF "INDIAN SPRINGS" HOOD RIVER COUNTY, STATE OF OREGON.

THE SUBDIVISION PARCEL. A PARCEL OF LAND LOCATED IN LOT 7, SUNNYSIDE, IN A PORTION OF THE NORTHWEST QUARTER OF SECTION 2, TOWNSHIP 2 NORTH, RANGE 10 EAST, WILLAMETTE MERIDIAN IN THE COUNTY OF HOOD RIVER AND STATE OF OREGON, BEING MORE PARTICULARLY DESCRIBED AS FOLLOWS:

BEGINNING AT THE NORTHWEST CORNER OF SAID LOT 7 OF SUNNYSIDE SUBDIVISION. THENCE SOUTH 89° 00' 52" EAST ALONG THE NORTH LINE OF SAID LOT 7 A DISTANCE OF 630.13 FEET TO A POINT 10.00 FEET WESTERLY OF THE NORTHEAST CORNER OF SAID LOT 7; THENCE SOUTH 1° 30' 29" WEST PARALLEL WITH THE EAST LINE OF SAID LOT 7 A DISTANCE OF 214.14 FEET TO THE THREAD OF INDIAN CREEK; THENCE FOLLOWING THE THREAD OF INDIAN CREEK ALONG THE FOLLOWING COURSES AND DISTANCES TO THE SOUTH LINE OF SAID LOT 7:

SOUTH 64° 37' 53" WEST, 34.93' FEET
SOUTH 18° 35' 56" WEST, 63.31' FEET
SOUTH 28° 52' 50" WEST, 32.64' FEET
SOUTH 10° 36' 15" WEST, 11.47' FEET
THENCE NORTH 89° 01' 21" WEST ALONG THE SOUTH LINE OF SAID LOT 7 A DISTANCE OF 127.73 FEET; THENCE ALONG THE FOLLOWING COURSES AND DISTANCES TO THE WEST LINE OF SAID LOT 7:
NORTH 29° 44' 05" WEST, 59.12' FEET
NORTH 23° 47' 23" WEST, 69.34' FEET
NORTH 55° 43' 17" WEST, 55.19' FEET
NORTH 00° 59' 08" EAST, 26.06' FEET
NORTH 89° 00' 52" WEST, 80.83' FEET
SOUTH 00° 59' 08" WEST, 29.69' FEET
SOUTH 72° 01' 30" WEST, 37.82' FEET
SOUTH 45° 10' 57" WEST, 36.16' FEET
SOUTH 43° 02' 25" WEST, 29.94' FEET
SOUTH 53° 38' 39" WEST, 38.44' FEET
NORTH 73° 51' 31" WEST, 38.10' FEET
SOUTH 35° 27' 32" WEST, 54.79' FEET
SOUTH 85° 19' 59" WEST, 70.70' FEET
THENCE NORTH 1° 33' 33" EAST LONG THE WEST LINE OF SAID LOT 7 A DISTANCE OF 315.64 FEET TO THE POINT OF BEGINNING.

EXCEPTING THEREFROM ANY LANDS WHICH MAY BE CONTAINED WITHIN EXISTING PUBLIC STREETS AND ROADS. CONTAINS 3.76 ACRES, MORE OR LESS.

TOGETHER WITH THE FOLLOWING DESCRIBED PARCEL LOCATED IN THE NORTHEAST QUARTER OF SECTION 3, TOWNSHIP 2 NORTH, RANGE 10 EAST, W.M., HOOD RIVER COUNTY, OREGON. SAID PARCEL TO BE USED FOR AS FOLLOWS. THE TOTAL PARCEL IS DEDICATED TO THE PUBLIC FOR ROAD RIGHT OF WAY AND UNDERGROUND UTILITY PURPOSES. THE SOUTH 60.00 FEET IN EVEN WIDTH OF WHICH IS DEDICATED AS A PERMANENT DEDICATION TO THE PUBLIC AND THE REMAINING PARCEL OF WHICH IS DEDICATED TEMPORARILY TO THE PUBLIC ONLY UNTIL ARROWHEAD AVENUE IS EXTENDED WEST.

COMMENCING AT THE NORTHWEST CORNER OF LOT 7, SUNNYSIDE, TO THE COUNTY OF HOOD RIVER. THENCE SOUTH 1° 33' 33" WEST ALONG THE WEST LINE OF SAID LOT 7 A DISTANCE OF 44.00 FEET TO THE POINT OF BEGINNING. THENCE NORTH 89° 00' 52" WEST A DISTANCE OF 127.15 FEET; THENCE SOUTH 1° 33' 33" WEST PARALLEL WITH THE WEST LINE OF SAID LOT 7 A DISTANCE OF 116.00 FEET; THENCE SOUTH 89° 00' 52" EAST A DISTANCE OF 127.15 FEET; THENCE NORTH 1° 33' 33" EAST ALONG THE WEST LINE OF SAID LOT 7 A DISTANCE OF 116.00 FEET TO THE POINT OF BEGINNING. EXCEPTING THEREFROM ANY LANDS WHICH MAY BE CONTAINED WITHIN EXISTING PUBLIC STREETS AND ROADS.

REGISTERED PROFESSIONAL LAND SURVEYOR

OREGON
JULY 13, 1979
ROY O. GAYLORD
1815

Expires June, 1999

Janis S. Gaylord
SUBSCRIBED AND SWORN BEFORE ME
THIS 17th DAY OF November, 1997.

OFFICIAL SEAL
JANIS S. GAYLORD
NOTARY PUBLIC - OREGON
COMMISSION NO. 025809
MY COMMISSION EXPIRES DEC. 12, 1997

THE PLAT OF INDIAN SPRINGS WAS EXAMINED AND APPROVED BY ME
THIS 25th DAY OF NOVEMBER, 1997
Ronald K. Braddy
CITY OF HOOD RIVER ENGINEER

DEDICATION:

KNOW ALL PERSONS BY THESE PRESENTS THAT M & M REALTY, A PARTNERSHIP, DOES HEREBY MAKE, ESTABLISH AND DECLARE THE PLAT MAP TO BE A TRUE AND CORRECT MAP OF THE LAND OWNED AND LAID OUT BY M & M REALTY, A PARTNERSHIP, AS "INDIAN SPRINGS" SAID LAND BEING MORE PARTICULARLY DESCRIBED IN THE SURVEYOR'S CERTIFICATE HERETO ANNEXED AND M & M REALTY, A PARTNERSHIP, DOES HEREBY DEDICATE TO THE USE OF THE PUBLIC AS PUBLIC WAYS FOREVER ALL STREETS AND PUBLIC EASEMENTS, LOCATED IN SECTION 2.

KNOW ALL PERSONS BY THESE PRESENTS THAT BROOKSIDE, INC., DOES HEREBY MAKE, ESTABLISH AND DECLARE THE PLAT MAP TO BE A TRUE AND CORRECT MAP OF THE LAND OWNED AND LAID OUT BY BROOKSIDE, INC., AS "INDIAN SPRINGS". SAID LAND BEING MORE PARTICULARLY DESCRIBED IN THE SURVEYOR'S CERTIFICATE HERETO ANNEXED AND BROOKSIDE, INC., DOES HEREBY DEDICATE TO THE USE OF THE PUBLIC AS PUBLIC WAYS FOREVER ALL PUBLIC STREETS AND EASEMENTS LOCATED IN SECTION 3.

David A. Martin
DAVID A. MARTIN
M & M REALTY

Carl H. Martin
CARL H. MARTIN
M & M REALTY

Robert L. Hanel
ROBERT L. HANEL
BROOKSIDE, INC., PRESIDENT

ACKNOWLEDGEMENT:

STATE OF OREGON
COUNTY OF HOOD RIVER

BE IT REMEMBERED ON THIS 17th DAY OF November, 1997, BEFORE ME A NOTARY PUBLIC FOR THE STATE OF OREGON, PERSONALLY APPEARED THESE KNOWN TO ME, WHO BEING FIRST DULY SWORN, SAID THAT THEY DID SIGN THIS INSTRUMENT OF THEIR FREE AND VOLUNTARY ACT.

OFFICIAL SEAL
JANIS S. GAYLORD
NOTARY PUBLIC - OREGON
COMMISSION NO. 025809
MY COMMISSION EXPIRES DEC. 12, 1997

Janis S. Gaylord
SUBSCRIBED AND SWORN BEFORE ME

STATE OF OREGON
COUNTY OF HOOD RIVER

BE IT REMEMBERED ON THIS 20th DAY OF November, 1997, BEFORE ME A NOTARY PUBLIC FOR THE STATE OF OREGON, PERSONALLY APPEARED MR. HANEL KNOWN TO ME, WHO BEING FIRST DULY SWORN, SAID THAT HE DID SIGN THIS INSTRUMENT OF HIS FREE AND VOLUNTARY ACT.

OFFICIAL SEAL
JANIS S. GAYLORD
NOTARY PUBLIC - OREGON
COMMISSION NO. 025809
MY COMMISSION EXPIRES DEC. 12, 1997

Janis S. Gaylord
SUBSCRIBED AND SWORN BEFORE ME

OFFICIAL SEAL
JANIS S. GAYLORD
NOTARY PUBLIC - OREGON
COMMISSION NO. 025809
MY COMMISSION EXPIRES DEC. 12, 1997

NOTES

COVENANTS AND RESTRICTIONS TO BE RECORDED AS A SEPARATE HOMEOWNER'S ASSOCIATION DOCUMENT BUT IS MADE A PART OF THIS PLAT.

NO WATER RIGHTS APPURTENANT TO THIS PROPERTY.

THE ACCESS TO THE ADJUSTED LOT 8, SUNNYSIDE, ON THE SOUTHERLY SIDE OF ARROWHEAD AVENUE AND ALL LANDS SOUTHERLY OF THE THREAD OF INDIAN CREEK SHALL BE OWNED BY THE OWNERS OF RECORD OF SAID LOT 8 AND RESPONSIBLE FOR ITS CARE AND MAINTENANCE.

FILED

DEC 30, 1997

Richard G. Smith
COUNTY CLERK

DEPT 117

TERRA SURVEYING

DATE: NOVEMBER, 1997
PROJECT: 9644-2
P.O. BOX 617
HOOD RIVER, OREGON 97031
PHONE & FAX: (503) 386-4531
E-MAIL terra@gorge.net

PLAT OF
INDIAN SPRINGS

DEC 2 1997

Certified to be a true and correct copy of the ORIGINAL. Dept. of Records & Assessment by John J. Judd Deputy