

Oct 15 1 10 PM '97

NARRATIVE:

NO MAJOR DISCREPANCIES WERE FOUND.

NOTE:

NO WATER RIGHTS ARE APPURTENANT TO THE PROPERTY
NO SANITARY SEWER EASEMENT EXISTS FOR THE WESTERLY
TO EASTERLY SEWER LINE.

LOCATION OF SURVEY:

A PORTION OF LOT 24, ADAMS PARADISE
ACREAGE, IN THE SOUTHEAST QUARTER OF
SECTION 26, TOWNSHIP 3 NORTH, RANGE 10 EAST,
W.M. HOOD RIVER COUNTY, OR.

File Number 9722
Instrument received on the 15 day of
Oct, 1997 at 1:10 P.M.

Hood River County Director of Records
and assessments.

SURVEYOR'S CERTIFICATE

I, ROY O. GAYLORD,
being first duly sworn, depose and say that I have
correctly surveyed and marked with proper
monuments the lands represented on this Partition
Plat, the boundaries being described in Instrument
660735, dated April 19, 1966
Hood River County Deed Records to

ALONZO & LARVERNE HENDERSON

REGISTERED
PROFESSIONAL
LAND SURVEYOR

OREGON
JULY 13, 1979
ROY O. GAYLORD
1815

Expires: June, 1999

ACKNOWLEDGEMENTS

We the owner(s) of the land shown herein, hereby
declare that this division of land has been made with
our free consent and in accordance with our desires.

Ladd Henderson 10/15/97
OWNER DATE

OWNER DATE

OWNER DATE
STATE OF Oregon
COUNTY OF Hood River } s.s.

Subscribed and sworn to before me on this
15th day of October, 1997

by Janis S. Gaylord

OFFICIAL SEAL
JANIS S. GAYLORD
NOTARY PUBLIC - OREGON
COMMISSION # 12345678
MY COMMISSION EXPIRES DEC. 12, 1997

(Seal)

APPROVALS

I hereby certify that all taxes and assessments due
hereon have been fully paid as required by law.

Daniel S. Chambers, CPA
Hood River County Director of Budget and
Finance

I hereby certify this partition was ex-
amined and approved as of this 15 day
of Oct, 1997.

Richard G. Arnold
Hood River County Surveyor

I hereby certify this partition was ex-
amined and approved as of this 15th day
of October, 1997.

Planning File Number 97-45 (Minor)
R. S. Wiley
Hood River City Planning Director

PREVIOUSLY FOUND NORTHWEST
CORNER OF LOT 24, A.P.A.

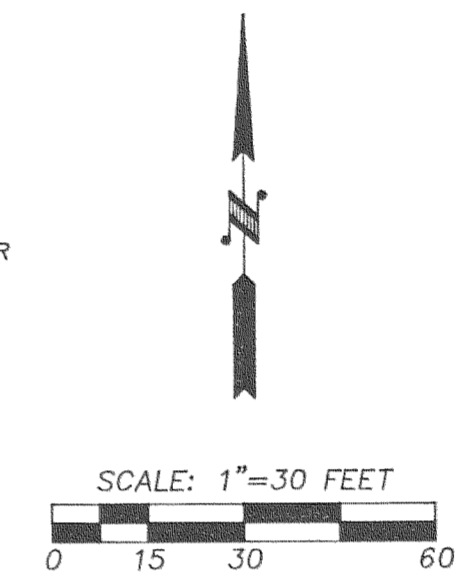
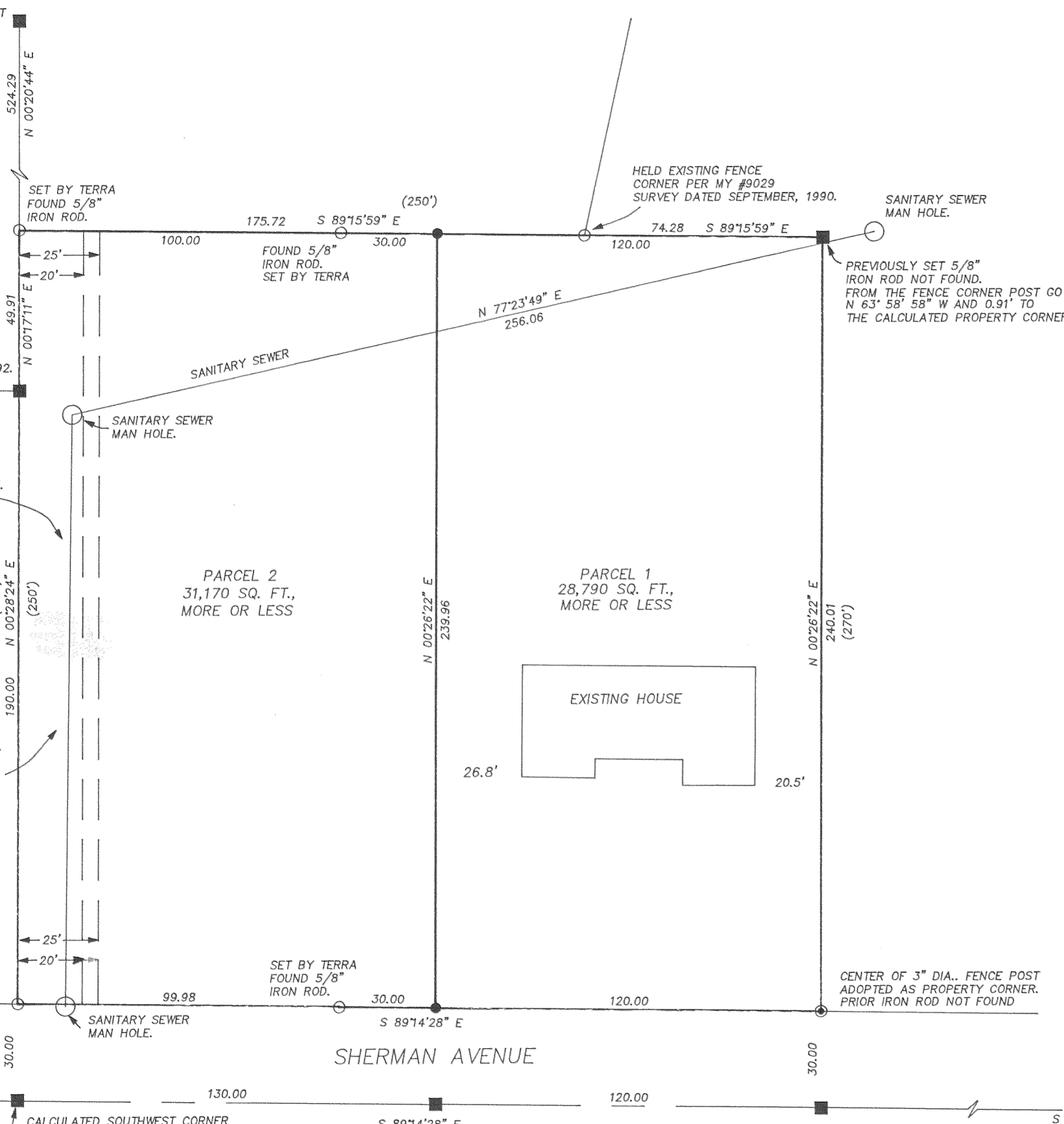

BASIS OF BEARING:

1986 CITY OF HOOD RIVER DATUM.

REFERENCES:

TERRA SURVEYING PROJECT No. 9250,
DATED DECEMBER 1992, FOR ALONZO HENDERSON.

LEGEND:

- SET 5/8" X 30" IRON ROD WITH PLASTIC CAP
- FOUND MONUMENT OF RECORD
- CALCULATED, NOT FOUND OR SET
- () DEED OR PLAT CALL

20.00' PUBLIC UTILITY EASEMENT &
ABANDONMENT OF PRIOR BOOK 28
@ PAGE 58 EASEMENT. SEE NEW
INSTRUMENT 902871, RECORDED
NOVEMBER 14, 1990.
CONTAINS DOMESTIC WATER,
STORM WATER AND SANITARY
SEWER LINES.

25.00' EASEMENT DEED TO JESSE M.
PUDDY, BOOK 50 @ PAGE 532.

FILED

NOV 24, 1997

Richard G. Arnold
COUNTY SURVEYOR

PARTITION PLAT

for

LADD HENDERSON, EXECUTOR OF
THE ALONZO HENDERSON ESTATE.

OCT 15 1997
Certified to be a true and
correct copy of the ORIGINAL,
Dept. of Records & Assessment
by J. Judd, Deputy

TERRA SURVEYING

DATE: SEPTEMBER, 1997
SCALE: 1" = 30'
PROJECT: 9744

P.O. BOX 617
HOOD RIVER, OREGON 97031

PHONE & FAX: (541) 386-4531
EMAIL: terra@gorge.net