

AREA TABLE

TRACT 1 EXISTING:	0.279 ACRES
TRACT 1 PROPOSED:	0.337 ACRES
TRACT 2 EXISTING:	6.772 ACRES
TRACT 2 PROPOSED:	6.714 ACRES

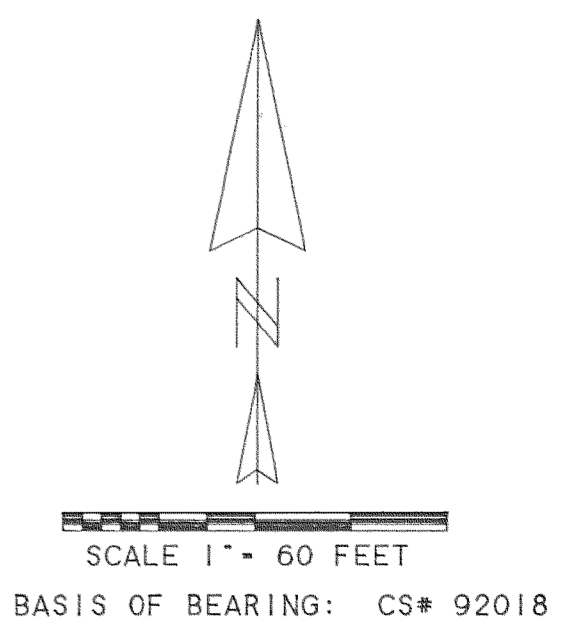

NARRATIVE

THE PURPOSE OF THIS SURVEY IS TO FILE FOR RECORD AND TO MONUMENT THE PROPOSED LINES OF A PROPERTY LINE ADJUSTMENT BETWEEN TAX LOTS 200 AND 300, 2N 10 2A, TAX LOT 200 IS DESCRIBED IN DEED RECORDED AT BOOK 24, PAGE 424, TAX LOT 300 IS DESCRIBED IN DEEDS RECORDED AT BOOK 55, PAGE 367 AND BOOK 64, PAGE 159. THE BOUNDARIES WERE ESTABLISHED PARALLEL WITH THE NORTH AND EAST LINES OF THE SECTION AT DEED DISTANCE.

BOOK 24, PAGE 424

TRACT 2
6.714 ACRES

NOTE: A DEED EXCEPTION CONTAINED IN BOOK 24, PAGE 424 FOR A STRIP OF LAND OFF THE SOUTH SIDE OF THIS TRACT AS QUITCLAIMED BY JOHN COOK AND WIFE TO R.R. IMBLER WAS NOT SURVEYED AND IS NOT SHOWN ON THIS MAP.

FILED
AUG 13, 1997
Richard A. Hall
COUNTY SURVEYOR

REGISTERED PROFESSIONAL LAND SURVEYOR
Kevin Dowd
OREGON
JULY 26, 1989
KEVIN DOWD
2393
RENEW DATE: 12-31-97
JULY 17, 1997

PROPERTY LINE ADJUSTMENT

SITUATED IN THE NORTHEAST QUARTER OF SECTION 2 T2 NORTH, R10 EAST, W.M. HOOD RIVER COUNTY, OREGON

FOR: NANCY EWALD

WYEAST SURVEYS
KEVIN DOWD
4399 WOODWORTH DR
MT HOOD OR, 97041
(541) 352-6065

LEGEND

- SET 5/8" IRON ROD WITH YELLOW PLASTIC CAP STAMPED "WYEAST SURVEYS PLS 2393"
- FOUND RAILROAD SPIKE AS PER CS# 90102
- ⊙ FOUND 5/8" IRON ROD AS PER CS# 92018