

FD 1/2" IRON ROD  
SET BY PLS 1028  
LATITUDE = 45°39'11.797" N  
LONGITUDE = 121°30'44.567" W

ADJUSTED AREA =  
44,970 SQ. FT. INCLUDING  
4,990 SQ. FT. IN VAN HORN DRIVE

ANGLE POINT  
AS PER PLS 1028  
SURVEYING

(PLS 1028 = 231.78')  
FD BRASS CAP  
NE COR SW 1/4  
SE 1/4 SEC 13

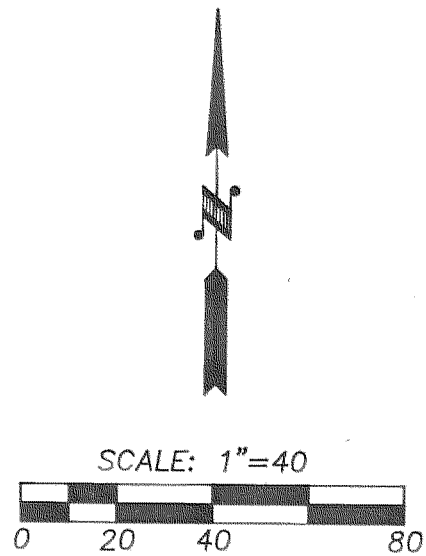

REGISTERED  
PROFESSIONAL  
LAND SURVEYOR

*Roy O. Gaylord*  
OREGON  
JULY 13, 1979  
ROY O. GAYLORD  
1815

**NARRATIVE:**

NO MAJOR DISCREPANCIES WERE FOUND. PLEASE NOTE THE ANGLE POINT IN THE 1/16 LINE. THE POINT WAS PERPETUATED SO AS NOT TO DISRUPT EXISTING SURVEYS IN THE AREA.

**LOCATION OF SURVEY:**

THE SOUTHWEST QUARTER OF THE SOUTHEAST QUARTER OF SECTION 13, TOWNSHIP 2 NORTH, RANGE 10 EAST, W.M., HOOD RIVER COUNTY, OREGON.

**BASIS OF BEARING:**

NAD 1983 DATUM

**REFERENCES:**

COUNTY SURVEY (CS) # 8611  
CS # 8618  
PLS 1028 SURVEY FILED 12-02-1982  
PLS 1028 SURVEY FILED 12-22-1988

**LEGEND:**

- SET 5/8" X 30" IRON ROD W/CAP
- FOUND MONUMENT OF RECORD
- CALCULATED, NOT FOUND OR SET
- ( ) DEED OR PLAT CALL

**TERRA SURVEYING**

DATE: JULY, 1995  
SCALE: 1" = 40'  
PROJECT: 9518

P.O. BOX 617  
HOOD RIVER, OREGON 97031  
PHONE & FAX: (503) 386-4531

**FILED**

JUL 19, 1995  
*Rachel A. Smith*  
COUNTY CLERK

PROPERTY LINE ADJUSTMENT SURVEY  
for  
PINE GROVE FIRE DEPARTMENT