

PARTITION IN  
SE 1/4, SEC 2, T 2 N, R 10 E, WM  
COUNTY OF HOOD RIVER, STATE OF OREGON

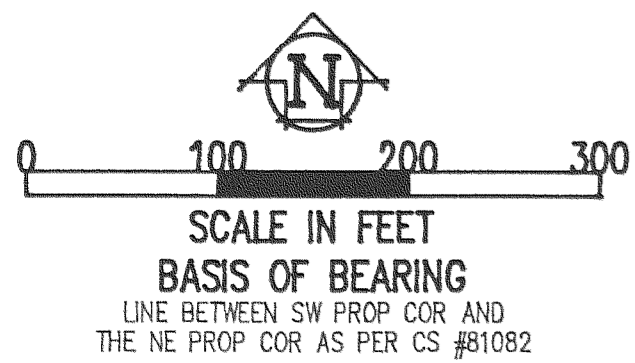

- LEGEND**
- = SET 5/8" IR WITH PLASTIC CAP MARKED OR #932 & WA #22098 EXCEPT AS NOTED
  - = FOUND 1/2" IRON ROD AS PER CS #81082
  - = CALCULATED CORNER AS PER CS #81082
  - ⊠ = CALCULATED 1/4 COR AS NOTED
  - ⊗ = CALCULATED SEC COR AS NOTED
  - ⊡ = FOUND 1/4 COR AS NOTED
  - ⊛ = FOUND SEC COR AS NOTED

**REFERENCE SURVEYS**  
SURVEY BY DLC SURVEYING, AUG 1981  
CS #81082

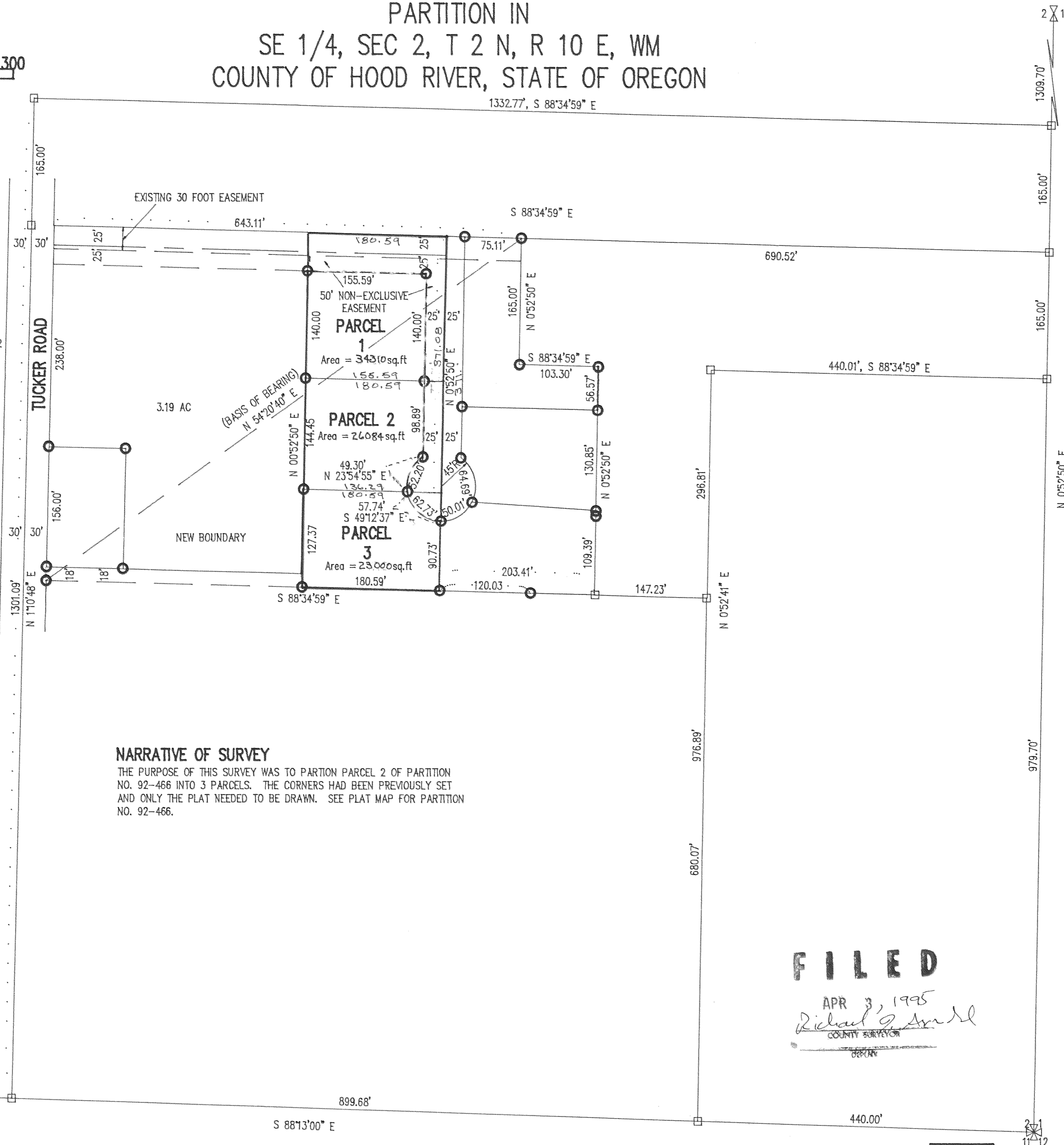

**NARRATIVE OF SURVEY**

THE PURPOSE OF THIS SURVEY WAS TO PARTION PARCEL 2 OF PARTITION NO. 92-466 INTO 3 PARCELS. THE CORNERS HAD BEEN PREVIOUSLY SET AND ONLY THE PLAT NEEDED TO BE DRAWN. SEE PLAT MAP FOR PARTITION NO. 92-466.

PARTITION FOR  
UNITED PENTECOSTAL CHURCH  
OF HOOD RIVER

MAR 21 1995  
Certified to be a true and correct copy of the ORIGINAL.  
Dept. of Records & Assessment  
by *J. Judd*; Deputy

**WATER RIGHT STATEMENT**  
WATER RIGHTS ARE SUBJECT SUBJECT TO THE STATUTORY POWERS OF FARMERS IRRIGATION DISTRICT AND ICE FOUNTAIN WATER DISTRICT. NO OTHER WATER RIGHTS EXIST.

REGISTERED PROFESSIONAL LAND SURVEYOR  
*Anthony C. Klein*  
OREGON  
JULY 17, 1970  
ANTHONY C. KLEIN  
932  
DATE: MAR 1995  
JOB NO.: 92062

**Klein & Assoc.**  
LAND SURVEYING  
1109 Country Club Road  
Hood River, Oregon 97031  
Tel: (503)386-3322

FILED  
RECORDS AND ASSESSMENT  
HOOD RIVER CO.  
MAR 21 10 20 AM '95

PARTITION PLAT NO. 9511

Instrument received on the 21 day of March, 1995 at 10:20 AM

Hood River County Director of Records and Assessments

**SURVEYS CERTIFICATE**

I, Anthony C. Klein, being first duly sworn, depose and say that I have correctly surveyed and marked with proper monuments the lands represented on this Partition Plat, the boundaries being described in Instrument No. 850914 dated May 21, 1985, Hood River County Records, to United Pentecostal Church of Hood River.

*Anthony C. Klein*  
ANTHONY C. KLEIN PLS 932

**ACKNOWLEDGEMENTS**

We the owners of the land shown herein, hereby declare that this division of land has been made with our free consent and in accordance with our desires.

*Raymond A. Sirstad* 3-21-95  
Raymond A. Sirstad - Pastor Date

United Pentecostal Church of Hood River  
OFFICIAL SEAL  
NICOLE D. ANDREWS  
NOTARY PUBLIC - OREGON  
COMMISSION NO. 041073  
MY COMMISSION EXPIRES JAN 25 1999  
STATE OF OREGON

COUNTY OF Hood River

Subscribed and sworn to before me on this 21 day of March, 1995  
by *Richard G. Arnold*

Notary Public for the State of Oregon  
My commission expires 1/26/99

**APPROVALS**

I hereby certify that all taxes and assessment due hereon have been fully paid as required by law.

*Daniel Guy Chamness, CPA*  
Hood River County Director of Budget and Finance.

I hereby certify this partition was examined and approved as of this 21 day of March, 1995

*Richard G. Arnold*  
Hood River County Surveyor

I hereby certify this partition was examined and approved as of this 21st day of March, 1995 (#95-036)

*Patricia Willy*  
Hood River County Planning Director

FILED  
APR 3, 1995  
*Richard G. Arnold*  
COUNTY SURVEYOR