

SURVEY IN THE  
SW 1/4, SEC 22, T 1 N, R 10 E, WM  
COUNTY OF HOOD RIVER, STATE OF OREGON

FILED  
RECORDS AND ASSESSMENT  
HOOD RIVER CO.

OCT 12 1992



SCALE IN FEET  
BASIS OF BEARING  
CS #90080-B

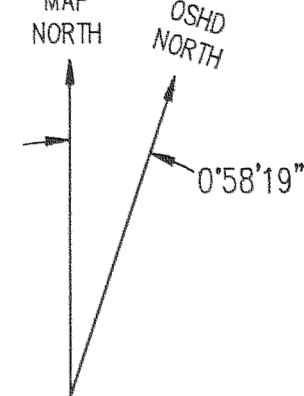

PARTITION PLAT NO. 9225  
9219

Instrument received on the 12 day of  
OCT, 1992 at 3:40 P.M.

Sandra E Berry  
Hood River County Director of Records  
and Assessments

SURVEYS CERTIFICATE

I, Anthony C. Klein, being first duly sworn, depose and say that I have correctly surveyed and marked with proper monuments the lands represented on this Partition Plat, the boundaries being described in Instrument No. 770370 dated February 16, 1977, and No. 772652 dated November 9, 1977, Hood River County Records, to Jess L. and Ruby L. Gross, husband and wife.

Anthony C. Klein 10/18/92  
ANTHONY C. KLEIN PLS 932

ACKNOWLEDGEMENTS

We the owners of the land shown herein, hereby declare that this division of land has been made with our free consent and in accordance with our desires.

Jess L. Gross 10/12/92  
Jess L. Gross Date  
Ruby L. Gross 10/12/92  
Ruby L. Gross Date

STATE OF OREGON }  
COUNTY OF Hood River } ss

Subscribed and sworn to before me on this  
12<sup>th</sup> day of October, 1992

by Yvonne Perwood

Notary Public for the State of Oregon  
My commission expires 4-7-95

APPROVALS

I hereby certify that all taxes and assessment due hereon have been fully paid as required by law.

Hood River County Director of Budget and Finance.

I hereby certify this partition was examined and approved as of this 12 day of Oct., 1992

Richard G. Arnold  
Hood River County Surveyor

I hereby certify this partition was examined and approved as of this 12<sup>th</sup> day of October, 1992

Minor Partition # 92-332  
Rose Thomas Wiley  
Planting Director - Hood River County

PI STA 505+35.76  
E=292.01, N=3207.94  
(E=90,948.92, N=26,678.14)

W 1/4 COR SEC 22  
FD CONC NAIL SET DURING  
PREVIOUS SURVEY  
SET BY COR REFERENCE  
E=344.08, N=3,005.13

OSHD CURVE CENTER LINE  
2'30" CR  
T= 40°57'30"  
Ts = 1107.53'  
2 - 500' SP'S  
S = 6'15"  
a = 0.5

PCS STA 499+28.23  
PS STA 494+28.23  
DIST & BEARING FROM SEC COR TO 1/4 COR  
(OSHD N 017° W  
N 1° 5' 19" W)

C/L RELOCATED HWY  
35 AS OF JULY 1991

OSHD TRAV PT, E=358.21, N=3274.12  
FD 5/8" IR WITH PLASTIC CAP  
(E=26,745.45, N=91,013.97)

LOT 2  
2.5 AC

LOT 1  
12.1 AC

[DEED 999' EAST]  
999.00', S 89°57'48" E

[DEED 666' EAST]  
666.00', S 89°57'48" E

[DEED 666' EAST]  
666.00', S 89°57'48" E

[DEED 666' EAST]  
666.00', S 89°57'48" E

[DEED 666' EAST]  
666.00', S 89°57'48" E

[DEED 666' EAST]  
666.00', S 89°57'48" E

[DEED 666' EAST]  
666.00', S 89°57'48" E

[DEED 666' EAST]  
666.00', S 89°57'48" E

[DEED 666' EAST]  
666.00', S 89°57'48" E

[DEED 666' EAST]  
666.00', S 89°57'48" E

[DEED 666' EAST]  
666.00', S 89°57'48" E

[DEED 666' EAST]  
666.00', S 89°57'48" E

[DEED 666' EAST]  
666.00', S 89°57'48" E

[DEED 666' EAST]  
666.00', S 89°57'48" E

[DEED 666' EAST]  
666.00', S 89°57'48" E

[DEED 666' EAST]  
666.00', S 89°57'48" E

[DEED 666' EAST]  
666.00', S 89°57'48" E

[DEED 666' EAST]  
666.00', S 89°57'48" E

[DEED 666' EAST]  
666.00', S 89°57'48" E

[DEED 666' EAST]  
666.00', S 89°57'48" E

[DEED 666' EAST]  
666.00', S 89°57'48" E

[DEED 666' EAST]  
666.00', S 89°57'48" E

[DEED 666' EAST]  
666.00', S 89°57'48" E

[DEED 666' EAST]  
666.00', S 89°57'48" E

[DEED 666' EAST]  
666.00', S 89°57'48" E

2656.97', S 89°57'48" E

FD 1/2" IP WITH BRASS TAG  
2.63', S 85°09'57" W  
FROM CAL COR

FD 2" IP WITH BRASS TAG  
0.23', S 26°26'10" W  
FROM CAL COR

CENTER SEC, SEC 22  
CAL AS PER FROST SURVEY  
WORK SHEET, CS #90080-B  
X=3,001.05, Y=3,003.42

STATEMENT OF WATER RIGHT  
THE PROPERTY IS UNDER THE JURISDICTION  
OF MT HOOD IRRIGATION DISTRICT.  
ALSO THERE IS A PORTION OF THE  
PROPERTY COVERED BY WATER RIGHT  
CERTIFICATE #15021

NOTE: A POSSIBLE GAP OR OVERLAP EXIST  
BECAUSE OF THE ADJOINING DESCRIPTIONS BEGINNING  
LOCATIONS. ONE BEGINS AT THE SW COR OF  
THE SECTION AND THE OTHER BEGINS AT THE  
WEST 1/4 COR. ALSO THERE IS AN APPARENT  
ERROR IN THE TRACT DESCRIBED IN BK 26, PG  
528. IT APPEARS TO BE IN THE MOST SOUTHERLY  
LINE TO THAT TRACT. I ADJUSTED THAT LINE AND  
CALCULATED THE BOUNDARY OF THE TRACT. I HELD  
THE CALLS OF THE GROSS DEED AS STATED IN THE  
DESCRIPTION.

DETAIL  
SEE NOTE

SW SEC COR SEC 22  
CAL AS PER FROST SURVEY  
WORK SHEET, CS #90080-B  
E=367.86, N=342.78

OSHD TRAV PT, E=377.21, N=-1,818.61  
FD 5/8" IR WITH PLASTIC CAP  
(E=26,677.96, N=85,921.65)

NARRATIVE OF SURVEY

THE PURPOSE OF THE SURVEY WAS TO ESTABLISH THE BOUNDARY OF TWO PARCELS AND TO DIVIDE ONE PARCEL INTO 2.5 ACRE LOTS FOR FUTURE PARTION. THE CENTER OF SECTION HAS BEEN IN CONTROVERSY BY TWO PREVIOUS SURVEYORS, WHICH HAVE DONE RECENT WORK IN THIS SECTION. ONE CALCULATED THE CENTER 1/4 AND THE OTHER USED A FOUND IP WITHIN A REASONABLE DISTANCE OF THE CALCULATED CORNER. I CHOOSE TO USE THE FOUND IP AS THE CENTER 1/4. TO ESTABLISH THE NEW RIGHT OF WAY FOR HWY 35 I TIED INTO TO OSHD TRAVEL STATIONS AND FROM A MAP FURNISHED BY OSHD AND CALCULATED THE RIGHT OF WAY. ALL MONUMENTS FOUND AND SET AND THE MEASURED BEARINGS AND DISTANCE ARE SHOWN HEREIN.

FILED

DEC 14, 1992

Richard G. Arnold  
COUNTY SURVEYOR  
DEPUTY

S 1/4 COR SEC 22  
FD BRASS CAP  
AS PER RECORD, AUG 1991  
E=3,026.54, N=191.71

DEC 9 1992

Certified to be a true and  
correct copy of the ORIGINAL.  
Dept. of Records & Assessment  
by J. Judd, Deputy

SURVEY FOR  
JESS & RUBY GROSS



Klein & Assoc.

REGISTERED  
PROFESSIONAL  
LAND SURVEYOR  
OREGON  
JULY 17, 1970  
ANTHONY C. KLEIN  
932  
LAND SURVEYING  
1109 Country Club Road  
Hood River, Oregon 97031  
Tele: (503)386-3322  
DATE SURVEYED: JULY 1991  
JOB NO.: 92017